

High Design and Construction Technology

Experience, knowledge and innovation, united to develop a compact, small footprint and lightweight equipment fully driven by a PLC.

The presence of emulsified oil in the bilge water of the latest generation vessels caused IMO to issue the resolution MEPC.107(49), which requires that the resulting effluent after bilge water treatment must contain levels below 15 ppm of surfactants.

The treatment of this type of water using traditional bilge water separators has resulted ineffective in achieving these results, so in order to comply with this resolution, in Facet we have developed the bilge water separators with ceramic membrane.

The combination of this technology together with Facet MPak® coalescent plates has allowed that our Facet CPS 3.2E + EMB Separators meet the strict requirements of the aforementioned IMO regulation.

Results

CPS 3.2E + EMB equipment eliminates hydrocarbons in two stages. In the first stage, the free hydrocarbon is separated from water through Facet coalescing plates, while in the second stage emulsions are broken by the ceramic membrane which removes emulsified hydrocarbon, reaching down an effluent with total hydrocarbon content of less than 5 ppm.

Standard Design Features

- Flow rate homologated: 0.73 m³/h (3.2 USGPM)
- Supplied ready to be installed
- No moving components other than pumps and pneumatic valves.
- Fixed control level, without float
- Very low maintenance, consisting in occasional hosing cleaning of the plates, and membrane's hot self-cleaning process. No chemicals needed in both operations
- Water presence less than 5% in the separated oil, so it can be burned if required
- Separated oil discharge facilitated by pump
- Power supply 380/440V, 50 or 60 Hz

Accessories

The equipment is supplied with the following accessories:

- Bilge alarm: as latest IMO MEPC. 107(49) resolution

Approvals

Facet CPS 3.2E + EMB has been tested, approved and certified according to the requirements of IMO MEPC.107(49).

Bilge Water Separators with Ceramic Membrane CPS 3.2E + EMB

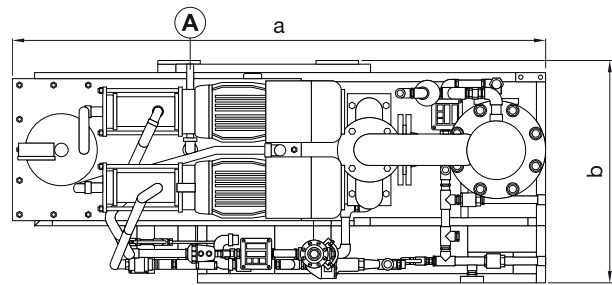
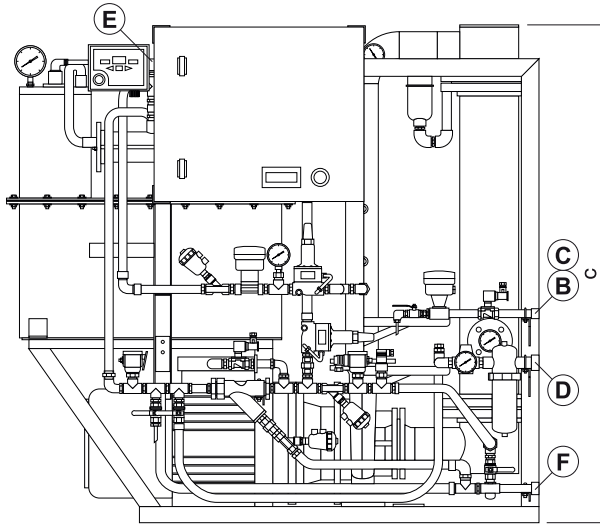

MARK	SERVICE
A	Oil / Water from bilge tank
B	Overboard discharge
C	Bilge back
D	Potable water inlet
E	Oil discharge
F	Common drain to bilge

MODEL	DIMENSIONS						EMPTY WEIGHT		WORKING WEIGHT	
	a		b		c		lbs	kg	lbs	kg
	in	mm	in	mm	in	mm				
CPS 3.2E +EMB	50 ³ / ₈	1280	24 ⁵ / ₈	625	70 ²⁷ / ₃₂	1800	1047	475	1322	600

08082024

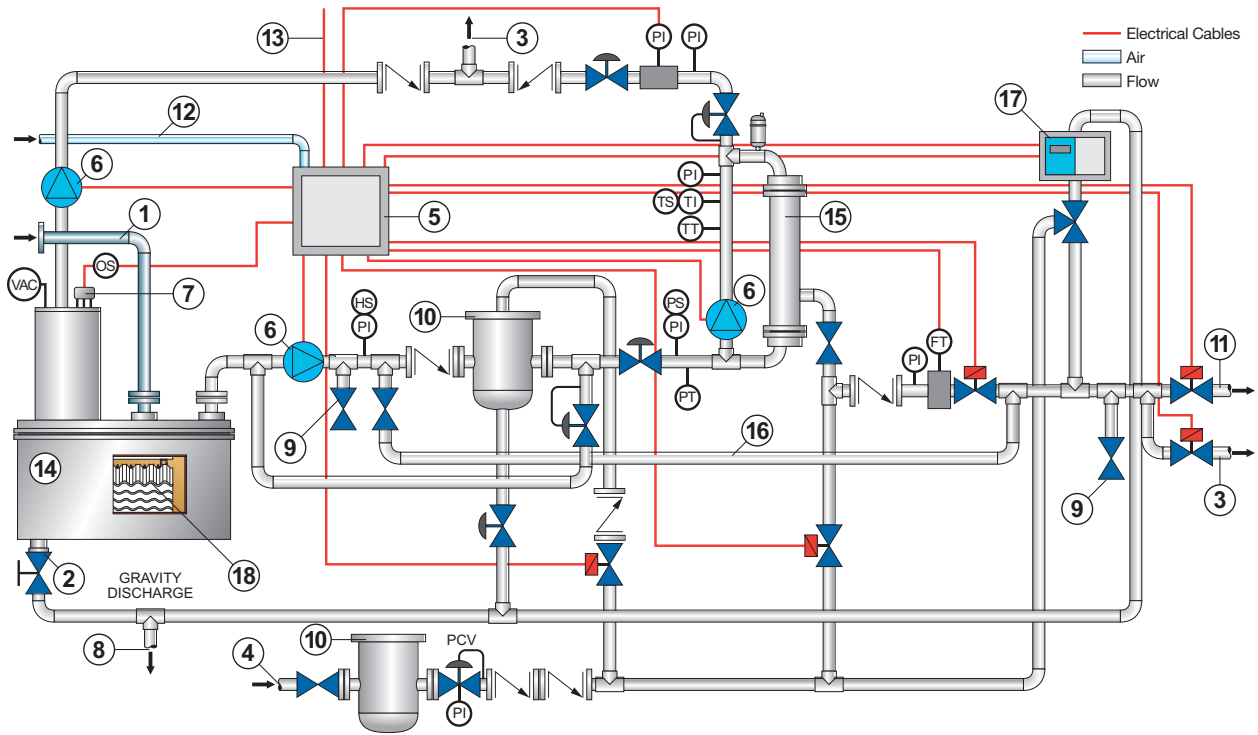

ITEM	DESCRIPTION
1	Oily water inlet line from bilge
2	Drain
3	Oil outlet
4	Pressure potable water
5	Control panel
6	Pump
7	Level control
8	Back to bilge line
9	Sample probe
10	Filter
11	Overboard water outlet line
12	Air line (customer supply)
13	Electrical line (customer supply)
14	Facet CPS 3.2E
15	Polishing module
16	Membrane by-pass
17	Bilge alarm
18	Facet MPak®