

These housings installed with one Fuel-Gard® monitor cartridge, will continually check the entire flow of fuel, not just mere samples, for water or solids contamination. By performing three jobs, this small compact monitor assures clean, dry fuel. It absorbs free and emulsified water, removes ultra-fine solids, and shuts down system flow when hit with a localized slug of water. Both interior and exterior surfaces of the carbon steel body are epoxy coated to protect against corrosion. This sturdy, single cartridge housing is easy to maintain and requires only 2" (51 mm) base clearance for cartridge change out.

Standard Housing Design

- Carbon steel body
- Aluminum head
- Epoxy coated internally and externally
- 150 psi (10.3 bar) design pressure
- Swing bolt quick open closure
- Buna-N o-ring closure gasket
- Vent and drain connections w/brass petcocks provided
- 1½" NPT inlet and outlet connections

VESSEL OPTIONS

MODEL	DESCRIPTION
VF-21SB	Housing only
VF-21SB-PG	Housing w/ Direct Reading Differential Pressure Gauge
VF-22SB	Housing only
VF-22SB-PG	Housing w/ Direct Reading Differential Pressure Gauge
644160	Mounting Bracket
644964	Grounding Cable
VF-21SB-PG2	Housing with 1/8" NPT connection to accommodate an external differential pressure gauge (supplied by others)
VF-22SB-PG2	Housing with 1/8" NPT connection to accommodate an external differential pressure gauge (supplied by others)

Differential Pressure Gauge- The piston-type differential pressure gauge provides a simple visual warning. When 15 psi (1.03 bar) differential pressure is reached, the gauge indicator moves from green to red zone. This warning will prevent premature cartridge change-out.

ACCORDING TO THE REQUIREMENTS OF EUROPEAN PRESSURE EQUIPMENT DIRECTIVE (PED) 2014/68/EU ART. 4.3, WITHIN THE OPERATING LIMITS PROVIDED ON VESSEL NAMEPLATE AND SUMMARIZED BELOW, THESE FILTERS ARE DESIGNED AND MANUFACTURED IN ACCORDANCE WITH THE SOUND ENGINEERING PRACTICE AND EXEMPT FROM CE MARKING AND CERTIFICATION: 10 BAR(G) @ 35°C FOR AV-GAS AND JET FUEL.

WARNING: MONITOR CARTRIDGES SHOULD NEVER BE USED WITH FUELS CONTAINING ANTI-ICING ADDITIVES SUCH AS FSII, PRIST AND DIGME. THIS INCLUDES PRE-MIXED AND MILITARY FUELS CONTAINING THESE ADDITIVES. THE USE OF MONITOR CARTRIDGES WITH FUELS CONTAINING ANTI-ICING ADDITIVES MAY RESULT IN (1) A FAILURE OF THE MONITOR CARTRIDGE AND/OR (2) MIGRATION OF FILTRATION MEDIA INTO THE FUEL STREAM, EITHER OF WHICH COULD POTENTIALLY CAUSE DAMAGE TO OR SUDDEN FAILURE OF THE CORRESPONDING ENGINE. THE SUPPLIER SHALL NOT BE LIABLE IN ANY RESPECT FOR ANY DAMAGE OR LOSS THAT ARISES FROM THE USE OF MONITOR CARTRIDGES WITH FUELS CONTAINING ANTI-ICING ADDITIVES. SUCH USE IS ENTIRELY AT THE USER'S RISK.

Fuel-Gard® VF-21SB/SB Monitor

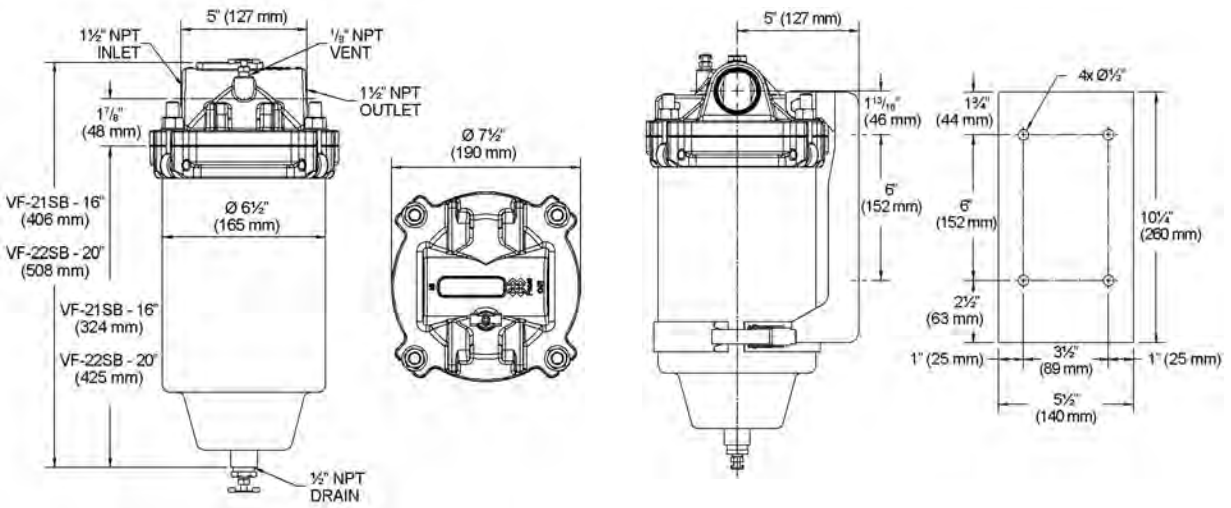

Optional Bonding Kit

The purpose of this bonding kit is to lessen the potential for static charge build up in the metal body of these vessels. This kit will allow the bowl, previously isolated because of the epoxy powder coating, to be bonded to system piping. One end of the bonding wire consists of a clamp that tightens onto the 1-1/2" piping. The other end has a heavy duty spring clamp that can be attached to the drain line valve. Remember if placing either end on a painted surface to scratch down to bare metal to allow contact.

This kit, part # 644964 can be purchased separately for existing vessels.



Optional Mounting Bracket



Standard Cartridge Design

- Tested to meet effluent requirements of EI 1583 latest edition
- Multi-layered media for increased solids holding, water removal and shutdown protection
- Flow direction: Outside to in
- Not adversely affected by exposure to temperatures varying from -65 °F to 160 °F (-54 °C to 71 °C)

Materials

- Carbon steel structural components
- Heavy duty metal center tube and outer shell for extra structural strength
- All metal components coated to protect against corrosion
- Standard gaskets are Buna-N—other materials available on request

The Facet Fuel-Gard® monitor cartridges meet the effluent requirements of the EI specification 1583 — Laboratory test and minimum performance levels for aviation fuel monitors.

The cartridge is made up of layered and pleated, multi-media sections with inner support shells and an outer wrap. A special water absorbent media retains water and the pleats expand. As the maximum water-holding capacity is reached, a reduction in flow occurs, indicating the cartridge should be changed. Maximum recommended operating temperature is 160 °F (71 °C).

DATA

MODEL NUMBER	OUTSIDE DIAMETER		NOMINAL LENGTH		SHIPPING WEIGHT		JET FUEL				AV-GAS			
							INITIAL ΔP		FLOW		INITIAL ΔP		FLOW	
	in	mm	in	mm	lbs	kg	psi	kPa	gpm	lpm	psi	kPa	gpm	lpm
21 SERIES														
FG-O-609-7	6	152	9	230	4	1.8	3.5	24.1	36	136	2.5	17.2	36	136
22 SERIES														
FG-O-612-7	6	152	12	300	6	2.7	5.5	37.9	48	182	3.5	24.1	48	182

* For applications other than AV-Gas and Jet Fuel, please contact the nearest Facet office.

**DP given for viscosity <2 cSt

WARNING: MONITOR CARTRIDGES SHOULD NEVER BE USED WITH FUELS CONTAINING ANTI-ICING ADDITIVES SUCH AS FSII, PRIST AND DI-EGME. THIS INCLUDES PRE-MIXED AND MILITARY FUELS CONTAINING THESE ADDITIVES. THE USE OF MONITOR CARTRIDGES WITH FUELS CONTAINING ANTI-ICING ADDITIVES MAY RESULT IN (1) A FAILURE OF THE MONITOR CARTRIDGE AND/OR (2) MIGRATION OF FILTRATION MEDIA INTO THE FUEL STREAM, EITHER OF WHICH COULD POTENTIALLY CAUSE DAMAGE TO OR SUDDEN FAILURE OF THE CORRESPONDING ENGINE. THE SUPPLIER SHALL NOT BE LIABLE IN ANY RESPECT FOR ANY DAMAGE OR LOSS THAT ARISES FROM THE USE OF MONITOR CARTRIDGES WITH FUELS CONTAINING ANTI-ICING ADDITIVES. SUCH USE IS ENTIRELY AT THE USER'S RISK.