

Donaldson®  
Facet™

# AVIATION

**Advancing Filtration for a Cleaner World**

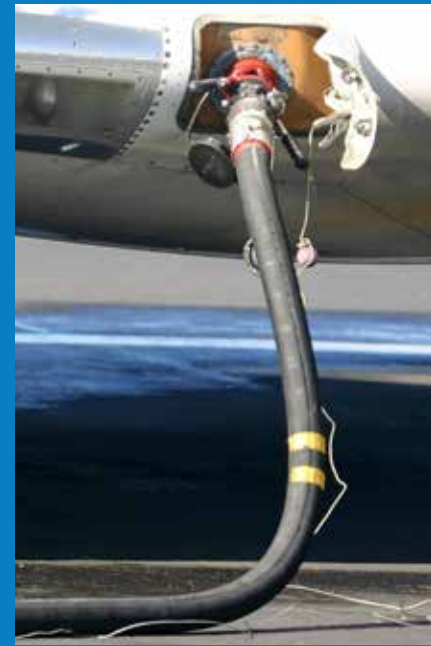



---

# TABLE OF CONTENTS

## Section 1 - Coalescer Separators

Coalescer Separators - General Description

Vertical Coalescer Separators

El 1581, 7th Edition, Category C, Type S

El 1581, 7th Edition, Category M, Type S

Horizontal Coalescer Separators

El 1581, 7th Edition, Category C, Type S

El 1581, 7th Edition, Category M, Type S

El 1581, 7th Edition, Category C, Type S-LW

El 1581, 7th Edition, Category M, Type S

El 1581, 7th Edition, Category C, Type S-LW

Vertical SuperFlex™ Coalescer Separators

Fuel-Gard® VF-21SB/22SB - Filter Water Separator

Fuel-Gard® VF-21SB/22SB

Electrical bonding kit

Portable Fuel Filtration and Pumping Set for Helicopters and Light Aircrafts

CAA Series 5 Coalescer Cartridges

SS-5 and ST-5 Series Separator Cartridges

CM Series Coalescer Cartridges

SM Series Separator Cartridges

CM100 Series Coalescer Cartridges

SM100 Series Separator Cartridges

## Section 2 - Clay Treaters

F Series - Clay Treater Housings

FS Series - SuperFlex™ Clay Treater Housings

Clay Treater Cartridges

Clay Treater Cartridges Mounting Arrangements

## Section 3 - Filters

M Series Filter Housings

MS Series SuperFlex™ Filter Housings

Fuel-Gard® VF-21SB/22SB Microfilter

Fuel-Gard® VF-21SB/22SB

Electrical bonding kit

FA-CIF Series Microfilter Cartridges El 1590 Qualified

FA Series Microfilter Cartridges El 1590 Qualified

M Series High Efficiency Pleated Paper Filter Cartridges

CIF Series Crushable Incinerable Cartridges

CIF Series - Center Tube Kit Installation Instructions

MPI Series - Flushing Pleated Paper Filter Cartridges

## Section 4 - Single-Stage Coalescers

HP Series - Single-Stage Coalescer Housings

Wafer Repack - Single-Stage Coalescers

## Section 5 - Technical Data

Cartridge Torque Recommendations

Standard Cartridge Mounting Hardware

Screw Base Adapter

Cleaning Procedures - Teflon® Screen and Synthetic Separator Cartridges

Frequently Asked Technical Questions

Liquid Filtration Application Information

Liquid Separation Application Information





Vertical Two-Stage Coalescer Separator Flow Diagram  
(including optional accessories)



Typical Horizontal End Opening Coalescer Separator Flow  
Diagram for Fixed Installation (including optional accessories)



Typical Horizontal End Opening Coalescer Separator Flow  
Diagram for Mobile Equipment

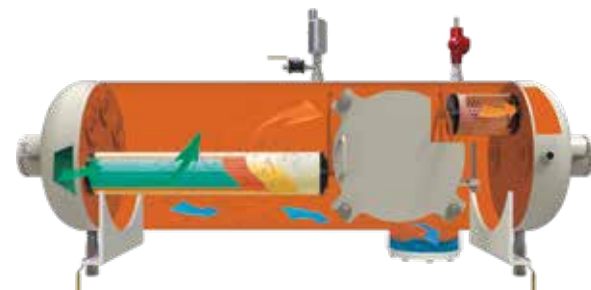

Typical Horizontal Side Opening Coalescer Separator Flow  
Diagram for Mobile Equipment

Two-stage coalescer separators are the primary defense against fuel contamination by water and dirt. The coalescer separator housings contain both first-stage coalescer and second-stage separator cartridges with no internal moving parts. The product is pumped under pressure to flow through the housing inlet chamber and inside/out through the multi-media coalescer cartridge. This specially developed multi-media cartridge configuration traps and holds minute solid particles to less than one micron, while forcing small water droplets to commingle and grow into heavier, larger drops that fall by gravity to the housing sump area. The cleaned fuel continues to flow outside/in through the second-stage separator cartridges. These separator cartridges strip any remaining water droplets from the fuel allowing only clean, dry fuel to pass.

Facet two-stage coalescer separators will continuously remove solids and water contaminants from aviation fuels. Vertical and horizontal housing designs are available with a wide selection of coalescer and separator cartridges to meet specific applications. Housings are designed for easy servicing and low maintenance. All are built to EI 1596 with many standard and optional accessories and connections available to facilitate piping and installation requirements. Facet coalescer separators provide a complete system that meets industry standards and individual levels of effluent purity required by commercial airlines, major oil companies and governments, worldwide.





Category C Coalescer Separator housings are for commercial aviation fuel. Type S qualifications can be used at all filtration points in an aviation fueling system. Type S is meant to be used at filtration points where significant levels of water and dirt in the product can be expected. Facet VCS Series Vertical Coalescer Separator housings fully comply with EI 1581, Category C, Type S requirements.

#### Reliable Performance

Facet coalescer separators are a result of 80 years of continuous research and development to meet the ever-demanding performance requirements in the aviation fuel handling industry. This, along with proven field performance, demonstrates Facet's ability to provide quality products that meet current specifications as well as specific customer requirements for installations in refineries, bulk storage terminals, heliports, airports, etc.

#### Standard Housing Design

- EI 1596 Design & Construction
- Welded carbon steel construction—other materials available on request
- ASME Code, Section VIII construction, stamped and certified
- Design pressure: 150 psi @ 250 °F (10.3 bar @ 121 °C) — other design pressures available on request
- Inlet, outlet and drain connections permanently marked
- Choice of rod or screw base coalescer cartridge mounting styles
- Interior: Epoxy coated (EI 1541)
- Exterior: Prime coated
- Swing bolt head closures
- Buna-N o-ring closure seal
- Knife edge cartridge mounting seals
- Headlift furnished on 18" (457 mm) OD and larger
- Spider plate attached to vessel wall
- Sloping cartridge plate to drain connection
- 4" inlet/outlet cleanout/inspection connections (when permitted by design)
- Connections provided for options listed below

#### Options

- Automatic air eliminator\* with check valve
- Pressure relief valve\*
- Differential pressure gauge\*
- Pilot control valve
- Pilot tester
- Water slug control valve
- Electrical water-level alarm
- Water drain valves
- Liquid level gauge
- Blind cover for pilot control mounting flange
- Immersion heaters
- Sampling probes\*
- Working platform and ladder

(\* Mandatory for EI 1596)

# VCS Series

## Vertical Coalescer Separators for

### EI 1581, 7th Edition, Category C, Type S

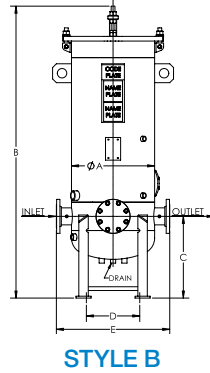
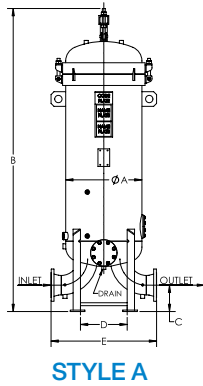

### DATA

MODEL NUMBER <sup>(1)</sup>	FLOW RATE		REQUIRED CARTRIDGES				HOUSING LIQUID VOLUME		HOUSING DRY WEIGHT		HOUSING TYPE
	AVIATION FUEL EI 1581, CAT. C, TYPE S		COALESCER		SEPARATOR						
	gpm	lpm	qty	Model	qty	Model	gal	ltr	lbs	kgs	
VCS-222-116	109	413	2	CAA22-5SB	1	SS616FB-5	35	132	525	238	Style B - Flat
VCS-328-218	222	840	3	CAA28-5SB	2	SS618FB-5	65	246	750	340	Style B - Flat
VCS-433-224	333	1261	4	CAA33-5SB	2	SS624FB-5	90	341	900	408	Style B - Flat
VCS-543-243	609	2305	5	CAA43-5SB	2	SS643FB-5	165	625	1200	544	Style A - Dished
VCS-556-340	782	2960	5	CAA56-5SB	3	SS640FB-5	180	681	1225	556	Style A - Dished
VCS-656-344	938	3551	6	CAA56-5SB	3	SS644FB-5	180	681	1250	567	Style A - Dished
VCS-756-440	1095	4145	7	CAA56-5SB	4	SS640FB-5	210	795	1525	692	Style A - Dished
VCS-856-444	1251	4736	8	CAA56-5SB	4	SS644FB-5	250	946	1675	760	Style A - Dished
VCS-1056-544	1564	5920	10	CAA56-5SB	5	SS644FB-5	320	1211	1875	850	Style A - Dished
VCS-1256-644	1877	7105	12	CAA56-5SB	6	SS644FB-5	385	1457	2575	1168	Style A - Dished
VCS-1356-744	2034	7700	13	CAA56-5SB	7	SS644FB-5	465	1760	2600	1179	Style A - Dished
VCS-1656-844	2500	9464	16	CAA56-5SB	8	SS644FB-5	530	2006	3000	1361	Style A - Dished

Other sizes available on request.

\* Separators: If preferred, Teflon® separator cartridges can be used. Consult Factory for flow rates.

The separator cartridge model number's prefix would change from SS to ST. Example: SS644FB-5 would change to ST644FB-5

### DIMENSIONS

MODEL NUMBER <sup>(1)</sup>	INLET/OUTLET DIAMETER		MAIN DRAIN	DIMENSIONS <sup>(2)</sup>									
				A		B		C		D		E	
	in	mm	in	in	mm	in	mm	in	mm	in	mm	in	mm
VCS-222-116	2	51	3/4	16	406	66 1/4	1683	20	508	10	254	24	610
VCS-328-218	3	76	3/4	20	508	73 1/2	1867	21	533	12 3/4	324	28	711
VCS-433-224	4	102	3/4	22	559	80 1/2	2045	21 3/4	552	14 1/4	362	30	762
VCS-543-243	6	152	3/4	26	660	103 1/2	2629	9	229	16	406	36	914
VCS-556-340	6	152	3/4	26	660	109 1/2	2781	9	229	16	406	36	914
VCS-656-344	6	152	3/4	26	660	109 1/2	2781	9	229	16	406	36	914
VCS-756-440	8	203	1 1/2	28	711	114 1/4	2902	10	254	17 1/2	445	45	1143
VCS-856-444	8	203	1 1/2	30	762	115	2921	10	254	19 1/2	495	46	1168
VCS-1056-544	8	203	1 1/2	34	864	117 1/2	2985	10	254	22 1/4	565	48	1219
VCS-1256-644	10	254	1 1/2	36	914	123 3/4	3143	11	279	24 1/4	616	55	1397
VCS-1356-744	10	254	1 1/2	38	1016	124 3/4	3169	11	279	26 1/2	673	56	1422
VCS-1656-844	12	305	1 1/2	42	1067	129 3/4	3296	12	305	28	711	66	1676

#### REFERENCE NOTES:

- (1) Model numbers include housing and required cartridges.
- (2) Dimensions are approximate and should not be used for installation purposes.

#### NOTES:

- All elements are mounted against knife edge seals.
- Nameplate to be stamped with EI classified data.
- Inlet chamber to be hydrostatic tested at 115 psi (7.9 bar).
- Coalescer cartridges are offered with a choice of rod or screw base mounting. The suffix "SB" will be added to the coalescer model number when screw base is required. Example: CAA28-5 = Rod Mount / CAA28-5SB = Screw Base



Category M Coalescer Separator housings are for Military F24, JP-8 or JP-5 fuel. Type S qualifications can be used at all filtration points in an aviation fueling system. Type S is meant to be used at filtration points where significant levels of water and dirt in the product can be expected. Facet VCS Series Vertical Coalescer Separator housings fully comply with EI 1581, Category M, Type S requirements.

### Reliable Performance

Facet coalescer separators are a result of 80 years of continuous research and development to meet the ever-demanding performance requirements in the aviation fuel handling industry. This, along with proven field performance, demonstrates Facet's ability to provide quality products that meet current specifications as well as specific customer requirements for installations in refineries, bulk storage terminals, heliports, airports, etc.

### Standard Housing Design

- EI 1596 Design & Construction
- Welded carbon steel construction—other materials available on request
- ASME Code, Section VIII construction, stamped and certified
- Design pressure: 150 psi @ 250 °F (10.3 bar @ 121 °C) — other design pressures available on request
- Inlet, outlet and drain connections permanently marked
- Choice of rod or screw base coalescer cartridge mounting styles
- Interior: Epoxy coated (EI 1541)
- Exterior: Prime coated
- Swing bolt head closures
- Buna-N o-ring closure seal
- Knife edge cartridge mounting seals
- Headlift furnished on 18" (457 mm) OD and larger
- Spider plate attached to vessel wall
- Sloping cartridge plate to drain connection
- 4" inlet/outlet cleanout/inspection connections (when permitted by design)
- Connections provided for options listed below

### Options

- Automatic air eliminator\* with check valve
- Pressure relief valve\*
- Differential pressure gauge\*
- Pilot control valve
- Pilot tester
- Water slug control valve
- Electrical water-level alarm
- Water drain valves
- Liquid level gauge
- Blind cover for pilot control mounting flange
- Immersion heaters
- Sampling probes\*
- Working platform and ladder

(\* Mandatory for EI 1596)

# VCS Series

## Vertical Coalescer Separators for

### EI 1581, 7th Edition, Category M, Type S

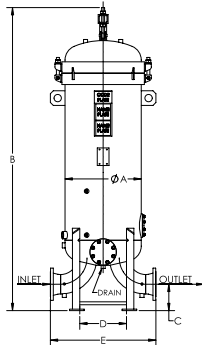

STYLE A

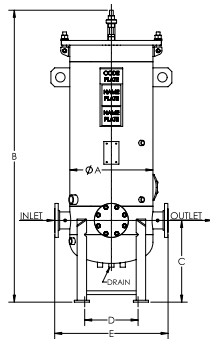

STYLE B



### DATA

MODEL NUMBER <sup>(1)</sup>	FLOW RATE		REQUIRED CARTRIDGES				HOUSING LIQUID VOLUME		HOUSING DRY WEIGHT		HOUSING TYPE
	AVIATION FUEL EI 1581 CAT. M, TYPE S		COALESCER		SEPARATOR		gal	ltr	lbs	kg	
	gpm	lpm	qty	Model	qty	Model					
VCS-222-116	85	322	2	CM-22SB-5	1	SM-16FB-5	35	132	525	238	Style B - Flat
VCS-328-218	173	655	3	CM-28SB-5	2	SM-18FB-5	65	246	750	340	Style B - Flat
VCS-433-224	260	984	4	CM-33SB-5	2	SM-24FB-5	90	341	900	408	Style B - Flat
VCS-543-243	474	1794	5	CM-43SB-5	2	SM-43FB-5	165	625	1200	544	Style A - Dished
VCS-556-340	609	2305	5	CM-56SB-5	3	SM-40FB-5	180	681	1225	556	Style A - Dished
VCS-656-344	730	2763	6	CM-56SB-5	3	SM-44FB-5	180	681	1250	567	Style A - Dished
VCS-756-440	852	3225	7	CM-56SB-5	4	SM-40FB-5	210	795	1525	692	Style A - Dished
VCS-856-444	974	3687	8	CM-56SB-5	4	SM-44FB-5	250	946	1675	760	Style A - Dished
VCS-956-540	1096	4149	9	CM-56SB-5	5	SM-40FB-5	285	1079	1800	816	Style A - Dished
VCS-1056-544	1218	4611	10	CM-56SB-5	5	SM-44FB-5	320	1211	1875	850	Style A - Dished
VCS-1256-644	1461	5530	12	CM-56SB-5	6	SM-44FB-5	385	1457	2575	1168	Style A - Dished
VCS-1356-744	1583	5992	13	CM-56SB-5	7	SM-44FB-5	465	1760	2600	1179	Style A - Dished
VCS-1656-844	1944	7359	16	CM-56SB-5	8	SM-44FB-5	530	2006	3000	1361	Style A - Dished

Other sizes available on request.

### DIMENSIONS

MODEL NUMBER <sup>(1)</sup>	INLET/OUTLET DIAMETER		MAIN DRAIN	DIMENSIONS <sup>(2)</sup>									
				A		B		C		D		E	
	in	mm	in	in	mm	in	mm	in	mm	in	mm	in	mm
VCS-222-116	2	51	3/4	16	406	66 1/4	1683	20	508	10	254	24	610
VCS-328-218	3	76	3/4	20	508	73 1/2	1867	21	533	12 3/4	324	28	711
VCS-433-224	4	102	3/4	22	559	80 1/2	2045	21 3/4	552	14 1/4	362	30	762
VCS-543-243	6	152	3/4	26	660	103 1/2	2629	9	229	16	406	36	914
VCS-556-340	6	152	3/4	26	660	109 1/2	2781	9	229	16	406	36	914
VCS-656-344	6	152	3/4	26	660	109 1/2	2781	9	229	16	406	36	914
VCS-756-440	8	203	1 1/2	28	711	114 1/4	2902	10	254	17 1/2	445	45	1143
VCS-856-444	8	203	1 1/2	30	762	115	2921	10	254	19 1/2	495	46	1168
VCS-956-540	8	203	1 1/2	32	813	115 3/4	2940	10	254	20 3/4	527	46	1168
VCS-1056-544	8	203	1 1/2	34	864	117 1/2	2985	10	254	22 1/4	565	48	1219
VCS-1256-644	10	254	1 1/2	36	914	123 3/4	3143	11	279	24 1/4	616	55	1397
VCS-1356-744	10	254	1 1/2	40	1016	124 3/4	3169	11	279	26 1/2	673	56	1422
VCS-1656-844	12	305	1 1/2	42	1067	129 3/4	3296	12	305	28	711	66	1676

#### REFERENCE NOTES:

- (1) Model numbers include housing and required cartridges.
- (2) Dimensions are approximate and should not be used for installation purposes.

#### NOTES:

- All elements are mounted against knife edge seals.
- Nameplate to be stamped with EI classified data.
- Inlet chamber to be hydrostatic tested at 115 psi (7.9 bar).
- Coalescer cartridges are offered with a choice of rod or screw base mounting. The suffix "SB" will be added to the coalescer model number when screw base is required. Example: CM-28-5 = Rod Mount / CM-28-5SB = Screw Base

### Horizontal Coalescer Separators for Fixed Installations EI 1581, 7th Edition, Category C, Type S



Category C Coalescer Separator housings are for commercial aviation fuel. Type S qualifications can be used at all filtration points in an aviation fueling system. Type S is meant to be used at filtration points where significant levels of water and dirt in the product can be expected. Facet HCS Series Horizontal Coalescer Separator housings fully comply with EI 1581, Category C, Type S requirements.

#### Reliable Performance

Facet coalescer separators are a result of 80 years of continuous research and development to meet the ever-demanding performance requirements in the aviation fuel handling industry. This, along with proven field performance, demonstrates Facet's ability to provide quality products that meet current specifications as well as specific customer requirements for installations in refineries, bulk storage, terminals, heliports, airports, etc.

#### Standard Housing Design

- EI 1596 Design & Construction
- Welded carbon steel construction—other materials available on request
- ASME Code, Section VIII construction, stamped and certified
- Design pressure: 150 psi @ 250 °F (10.3 bar @ 121 °C) — other design pressures available on request
- Inlet, outlet and drain connections permanently marked
- Interior: Epoxy coated (EI 1541)
- Exterior: Prime coated
- Swing bolt head closures
- Hinged end opening cover
- Flanged inlet and outlet connections
- Buna-N o-ring closure seal
- Choice of rod or screw base coalescer cartridge mounting styles
- 4" inlet/outlet cleanout/inspection connections (when permitted by design)
- Knife edge cartridge mounting seals
- Spider plate attached to vessel wall

#### Options

- Automatic air eliminator\* with check valve
- Pressure relief valve\*
- Differential pressure gauge\*
- Pilot control valve
- Pilot tester
- Water slug control valve
- Electrical water-level alarm
- Water drain valves
- Liquid level gauge
- Blind cover for pilot control mounting flange
- Immersion heaters
- Sampling probes\*

(\* Mandatory for EI 1596))

# HCS Series (End Opening)

## Horizontal Coalescer Separators for Fixed Installations

EI 1581, 7th Edition, Category C, Type S

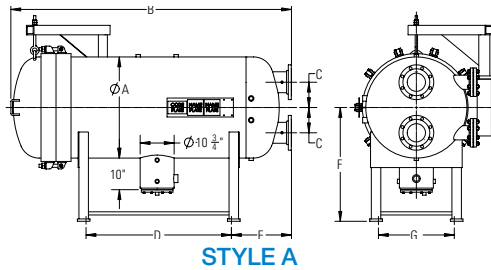

STYLE A

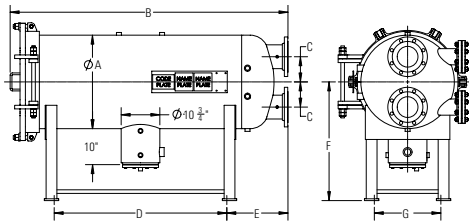
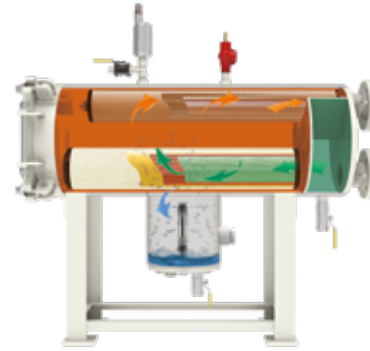

STYLE B

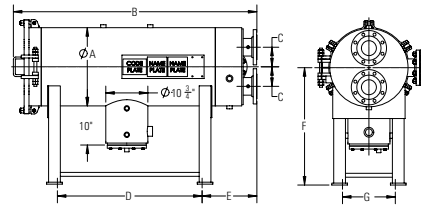

STYLE C

### DATA

MODEL NUMBER <sup>(1)</sup>	FLOW RATE		REQUIRED CARTRIDGES				HOUSING LIQUID VOLUME		HOUSING DRY WEIGHT		HOUSING TYPE
	AVIATION FUEL EI 1581 CAT. C, TYPE S		COALESCER		SEPARATOR		gal	ltr	lbs	kg	
	gpm	lpm	qty	Model	qty	Model					
HCS-222-1324	105	397	2	CAA22-5SB	1	SS324FA-5	24	91	425	193	Style C - Flat
HCS-322-1424	157	594	3	CAA22-5SB	1	SS424FB-5	29	110	500	227	Style C - Flat
HCS-333-1436	244	924	3	CAA33-5SB	1	SS436FB-5	38	144	550	249	Style C - Flat
HCS-343-133	334	1264	3	CAA43-5SB	1	SS633FF-5	60	227	700	318	Style C - Flat
HCS-443-143	445	1685	4	CAA43-5SB	1	SS643FF-5	72	273	775	352	Style C - Flat
HCS-556-233	686	2597	5	CAA56-5SB	2	SS633FF-5	107	405	950	431	Style B - Dished
HCS-756-248	1000	3785	7	CAA56-5SB	2	SS648FF-5	151	572	1325	601	Style B - Dished
HCS-856-340	1234	4671	8	CAA56-5SB	3	SS640FF-5	270	1022	1700	771	Style A - Dished
HCS-1056-348	1543	5841	10	CAA56-5SB	3	SS648FF-5	350	1325	1975	896	Style A - Dished

Other sizes available on request.

\* Separators: If preferred, Teflon® separator cartridges can be used in place of Synthetic.

The separator cartridge model number's prefix would change from SS to ST. Example: SS324FA-5 would change to ST324FA-5

### DIMENSIONS

MODEL NUMBER <sup>(1)</sup>	INLET/OUTLET DIAMETER		DIMENSIONS <sup>(2)</sup>													
			A		B		C		D		E		F		G	
	in	mm	in	mm	in	mm	in	mm	in	mm	in	mm	in	mm	in	mm
HCS-222-1324	2	51	14	356	41½	1054	4	102	18	457	13½	343	25	635	9½	241
HCS-322-1424	3	76	16	406	39¾	1010	5	127	16	406	13½	343	28	711	10	254
HCS-333-1436	3	76	16	406	50½	1283	5	127	26	660	14	356	28	711	10	254
HCS-343-133	4	102	18	457	62½	1588	5	127	38	965	14	356	29	737	12	305
HCS-443-143	4	102	20	508	62¼	1581	5	127	37	940	14	356	30	762	13½	343
HCS-556-233	6	152	22	559	76	1930	6	152	49	1245	15	381	31	787	15½	394
HCS-756-248	6	152	26	660	77½	1969	7	178	49	1245	16½	419	33	838	18½	470
HCS-856-340	6	152	32	813	89	2261	8	203	48	1219	18	457	36	914	24	610
HCS-1056-348	8	203	36	914	91	2311	8	203	48	1219	19	483	38	965	27	686

#### REFERENCE NOTES:

- (1) Model numbers include housing style and required cartridge mounting.
- (2) Dimensions are approximate and should not be used for installation purposes.

#### NOTES:

- All elements are mounted against knife edge seals.
- Nameplate to be stamped with EI classified data.
- Inlet chamber to be hydrostatic tested at 115 psi (7.9 bar).
- Coalescer cartridges are offered with a choice of rod or screw base mounting. The suffix "SB" will be added to the coalescer model number when screw base is required. Example: CAA33-5 = Rod Mount / CAA33-5SB = Screw Base

### Horizontal Coalescer Separators for Fixed Installations EI 1581, 7th Edition, Category M, Type S



Category M Coalescer Separator housings are for Military F24, JP-8 or JP-5 fuel. Type S qualifications can be used at all filtration points in an aviation fueling system. Type S is meant to be used at filtration points where significant levels of water and dirt in the product can be expected. Facet HCS Series Horizontal Coalescer Separator housings fully comply with EI 1581, Category M, Type S requirements.

#### Reliable Performance

Facet coalescer separators are a result of 80 years of continuous research and development to meet the ever-demanding performance requirements in the aviation fuel handling industry. This, along with proven field performance, demonstrates Facet's ability to provide quality products that meet current specifications as well as specific customer requirements for installations in refineries, bulk storage, terminals, heliports, airports, etc.

#### Standard Housing Design

- EI 1596 Design & Construction
- Welded carbon steel construction—other materials available on request
- ASME Code, Section VIII construction, stamped and certified
- Design pressure: 150 psi @ 250 °F (10.3 bar @ 121 °C) — other design pressures available on request
- Inlet, outlet and drain connections permanently marked
- Interior: Epoxy coated (EI 1541)
- Exterior: Prime coated
- Swing bolt head closures
- Hinged end opening cover
- Flanged inlet and outlet connections
- Buna-N o-ring closure seal
- Choice of rod or screw base coalescer cartridge mounting styles
- 4" inlet/outlet cleanout/inspection connections (when permitted by design)
- Knife edge cartridge mounting seals
- Spider plate attached to vessel wall

#### Options

- Automatic air eliminator\* with check valve
- Pressure relief valve\*
- Differential pressure gauge\*
- Pilot control valve
- Pilot tester
- Water slug control valve
- Electrical water-level alarm
- Water drain valves
- Liquid level gauge
- Blind cover for pilot control mounting flange
- Immersion heaters
- Sampling probes\*

(\* Mandatory for EI 1596)

# HCS Series (End Opening)

## Horizontal Coalescer Separators for Fixed Installations

### EI 1581, 7th Edition, Category M, Type S

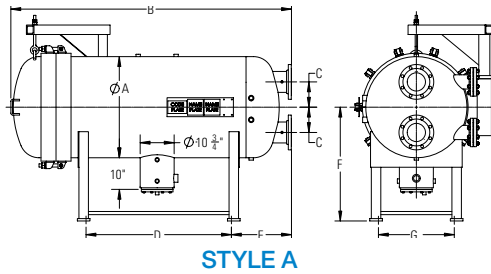

STYLE A

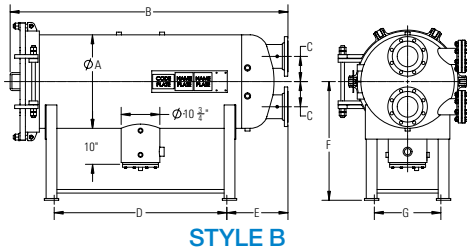
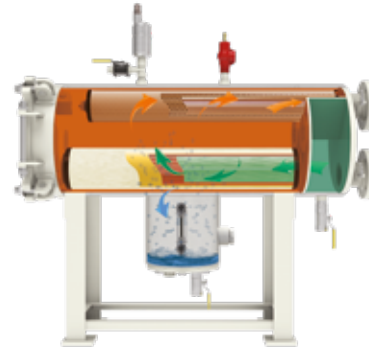

STYLE B

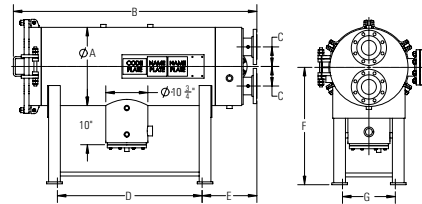

STYLE C

### DATA

MODEL NUMBER <sup>(1)</sup>	FLOW RATE		REQUIRED CARTRIDGES				HOUSING LIQUID VOLUME		HOUSING DRY WEIGHT		HOUSING TYPE
	AVIATION FUEL EI 1581 CAT. M, TYPE S		COALESCER		SEPARATOR						
	gpm	lpm	qty	Model	qty	Model	gal	ltr	lbs	kg	
HCS-322-1424	157	594	3	CM-22SB-5	1	SM-424FB-5	29	110	500	227	Style C - Flat
HCS-333-1436	243	920	3	CM-33SB-5	1	SM-436FB-5	38	144	550	249	Style C - Flat
HCS-438-138	302	1143	4	CM-38SB-5	1	SM-38FF-5	80	303	850	386	Style C - Flat
HCS-456-229	478	1809	4	CM-56SB-5	2	SM-29FB-5	129	488	1050	476	Style B - Dished
HCS-556-236	605	2290	5	CM-56SB-5	2	SM-36FF-5	151	572	1325	601	Style B - Dished
HCS-756-248	808	3059	7	CM-56SB-5	2	SM-48FF-5	226	856	1600	726	Style A - Dished

Other sizes available on request.

### DIMENSIONS

MODEL NUMBER <sup>(1)</sup>	INLET/OUTLET DIAMETER		DIMENSIONS <sup>(2)</sup>													
			A		B		C		D		E		F		G	
	in	mm	in	mm	in	mm	in	mm	in	mm	in	mm	in	mm	in	mm
HCS-322-1424	3	76	16	406	39 <sup>3</sup> / <sub>4</sub>	1010	5	127	16	406	13 <sup>1</sup> / <sub>2</sub>	343	28	711	10	254
HCS-333-1436	3	76	16	406	50 <sup>1</sup> / <sub>2</sub>	1283	5	127	26	660	14	356	28	711	10	254
HCS-438-138	3	76	22	559	57 <sup>1</sup> / <sub>4</sub>	1454	6	152	32	813	14	356	31	787	13 <sup>1</sup> / <sub>2</sub>	343
HCS-456-229	4	102	24	610	77 <sup>1</sup> / <sub>2</sub>	1969	6	152	48	1219	15	381	32	813	16 <sup>1</sup> / <sub>2</sub>	419
HCS-556-236	6	152	26	660	77 <sup>1</sup> / <sub>4</sub>	1969	7	178	48	1219	17	432	33	838	18 <sup>1</sup> / <sub>2</sub>	470
HCS-756-248	6	152	32	813	75 <sup>3</sup> / <sub>4</sub>	1924	8	203	33	838	19	483	36	914	24	610

#### REFERENCE NOTES:

- (1) Model numbers include housing style and required cartridge mounting.
- (2) Dimensions are approximate and should not be used for installation purposes.

#### NOTES:

- All elements are mounted against knife edge seals.
- Nameplate to be stamped with EI classified data.
- Inlet chamber to be hydrostatic tested at 115 psi (7.9 bar).
- Coalescer cartridges are offered with a choice of rod or screw base mounting. The suffix "SB" will be added to the coalescer model number when screw base is required. Example: CM-33-5 = Rod Mount / CM-33SB-5 = Screw Base

### Horizontal Coalescer Separators for Mobile Equipment EI 1581, 7th Edition, Category C, Type S-LW

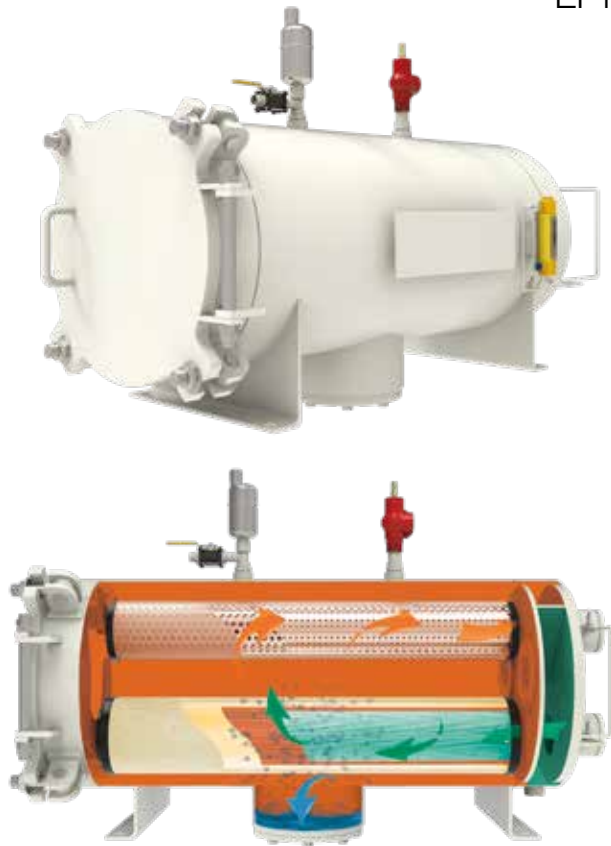

Category C Coalescer Separator housings are for commercial aviation fuel. Type S-LW qualification can be used for mobile applications where minimum amounts of water and dirt in the product are expected. Facet HCS Series Horizontal Coalescer Separator housings fully comply with EI 1581, Category C, Type S-LW requirements.

#### Reliable Performance

Facet coalescer separators are a result of 80 years of continuous research and development to meet the ever demanding performance requirements in the aviation fuel handling industry. This, along with proven field performance, demonstrates Facet's ability to provide quality products that meet current specifications as well as specific customer requirements for installations in refineries, bulk storage, terminals, heliports, airports, etc.

#### Standard Housing Design

- EI 1596 Design & Construction
- Welded carbon steel construction—other materials available on request
- ASME Code, Section VIII construction, stamped and certified
- Design pressure: 150 psi @ 250 °F (10.3 bar @ 121 °C) — other design pressures available on request
- Inlet, outlet and drain connections permanently marked
- Interior: Epoxy coated (EI 1541)
- Exterior: Prime coated
- Swing bolt head closures
- Hinged end opening cover
- Victaulic inlet and outlet connections
- Buna-N o-ring closure seal
- Choice of rod or screw base coalescer cartridge mounting styles
- Knife edge cartridge mounting seals
- 4" inlet/outlet cleanout/inspection connections (when permitted by design)
- Spider plate attached to vessel wall

#### Options

- Water defense system\*
- Automatic air eliminator\* with check valve
- Pressure relief valve\*
- Differential pressure gauge\*
- Pilot control valve
- Blind cover for pilot control mounting flange
- Sampling probes\*

(\* Mandatory for EI 1596)

# HCS Series (End Opening)

## Horizontal Coalescer Separators for Mobile Equipment

### EI 1581, 7th Edition, Category C, Type S-LW

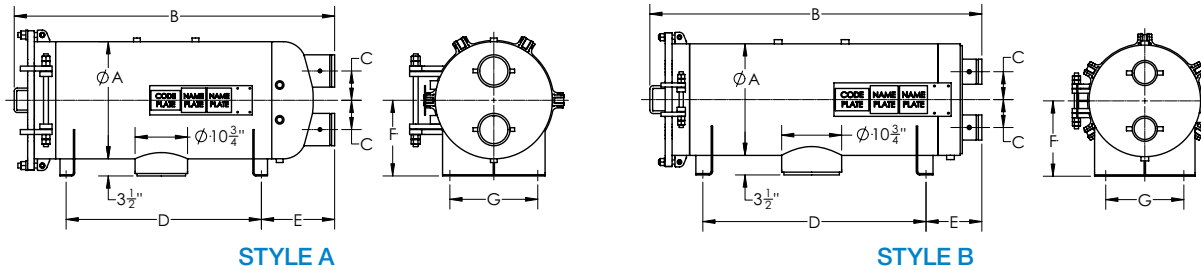

#### DATA

MODEL NUMBER <sup>(1)</sup>	FLOW RATE		REQUIRED CARTRIDGES				HOUSING LIQUID VOLUME		HOUSING DRY WEIGHT		HOUSING TYPE
	AVIATION FUEL EI 1581 CAT. C, TYPE S-LW		COALESCER		SEPARATOR		gal	ltr	lbs	kg	
	gpm	lpm	qty	Model	qty	Model					
HCS-216-1318	100	379	2	CAA16-5	1	SS318FA-5	16	61	250	113	Style B - Flat
HCS-322-1424	207	784	3	CAA22-5SB	1	SS424FB-5	27	102	350	159	Style B - Flat
HCS-333-1436	321	1215	3	CAA33-5SB	1	SS436FB-5	33	125	375	170	Style B - Flat
HCS-338-130	374	1416	3	CAA38-5SB	1	SS630FF-5	48	182	500	227	Style B - Flat
HCS-343-133	440	1666	3	CAA43-5SB	1	SS633FF-5	55	208	525	238	Style B - Flat
HCS-438-138	499	1889	4	CAA38-5SB	1	SS638FF-5	60	227	575	261	Style B - Flat
HCS-356-144	565	2139	3	CAA56-5SB	1	SS644FF-5	67	254	575	261	Style B - Flat
HCS-443-144	586	2218	4	CAA43-5SB	1	SS644FF-5	67	254	600	272	Style B - Flat
HCS-543-229	733	2775	5	CAA43-5SB	2	SS629FF-5	85	322	675	306	Style A - Dished
HCS-456-229	753	2850	4	CAA56-5SB	2	SS629FF-5	105	397	750	340	Style A - Dished
HCS-643-236	880	3331	6	CAA43-5SB	2	SS636FF-5	105	397	800	363	Style A - Dished
HCS-556-236	942	3566	5	CAA56-5SB	2	SS636FF-5	127	481	900	408	Style A - Dished
HCS-656-244	1130	4278	6	CAA56-5SB	2	SS644FF-5	150	568	1125	510	Style A - Dished
HCS-756-248	1317	4985	7	CAA56-5SB	2	SS648FF-5	149	564	1125	510	Style A - Dished

#### DIMENSIONS

MODEL NUMBER <sup>(1)</sup>	INLET/OUTLET DIAMETER		DIMENSIONS <sup>(2)</sup>													
			A		B		C		D		E		F		G	
	in	mm	in	mm	in	mm	in	mm	in	mm	in	mm	in	mm	in	mm
HCS-216-1318	2	51	14	356	32 3/4	832	4	102	18	457	8	203	10 1/2	267	9	229
HCS-322-1424	3	76	16	406	39 3/4	1010	5	127	21	533	9 3/4	248	11 1/2	292	11	279
HCS-333-1436	3	76	16	406	48	1219	5	127	28	711	10 3/4	273	11 1/2	292	11	279
HCS-338-130	4	102	18	457	53 3/4	1365	5	127	34	864	10 1/2	267	12 1/2	318	12	305
HCS-343-133	4	102	18	457	59 3/4	1518	5	127	40	1016	10 1/2	267	12 1/2	318	12	305
HCS-438-138	4	102	20	508	54	1372	5	127	35	889	9 3/4	248	13 1/2	343	14	356
HCS-356-144	4	102	18	457	71 1/2	1816	5	127	52	1321	10 1/4	260	12 1/2	318	12	305
HCS-443-144	4	102	20	508	59 1/2	1511	5	127	40	1016	10	254	13 1/2	343	14	356
HCS-543-229	6	152	22	559	63 1/2	1613	6	152	39	991	14	356	14 1/2	368	16	406
HCS-456-229	6	152	22	559	76 3/4	1949	6	152	52	1321	14	356	14 1/2	368	16	406
HCS-643-236	6	152	24	610	65 3/4	1670	6	152	40	1016	15	381	15 1/2	394	18	457
HCS-556-236	6	152	24	610	77 1/2	1969	6	152	52	1321	15	381	15 1/2	394	18	457
HCS-656-244	6	152	26	660	77 1/2	1969	7	178	52	1321	15	381	16 1/2	419	19	483
HCS-756-248	6	152	26	660	77 1/4	1962	8	203	52	1321	15	381	16 1/2	419	19	483

Other sizes available on request.

#### REFERENCE NOTES:

- (1) Model numbers include housing and required cartridge mounting.
- (2) Dimensions are approximate and should not be used for installation purposes.

#### NOTES:

- All elements are mounted against knife edge seals.
- Nameplate to be stamped with EI classified data.
- Inlet chamber to be hydrostatic tested at 115 psi (7.9 bar).
- Coalescer cartridges are offered with a choice of rod or screw base mounting. The suffix "SB" will be added to the coalescer model number when screw base is required. Example: CAA33-5 = Rod Mount / CAA33SB-5 = Screw Base
- Separators: If preferred, Teflon® separator cartridges can be used in place of Synthetic. The separator cartridge model number's prefix would change from SS to ST. Example: SS318FA-5 // ST318FA-5.

### Horizontal Coalescer Separators for Mobile Equipment EI 1581, 7th Edition, Category M, Type S

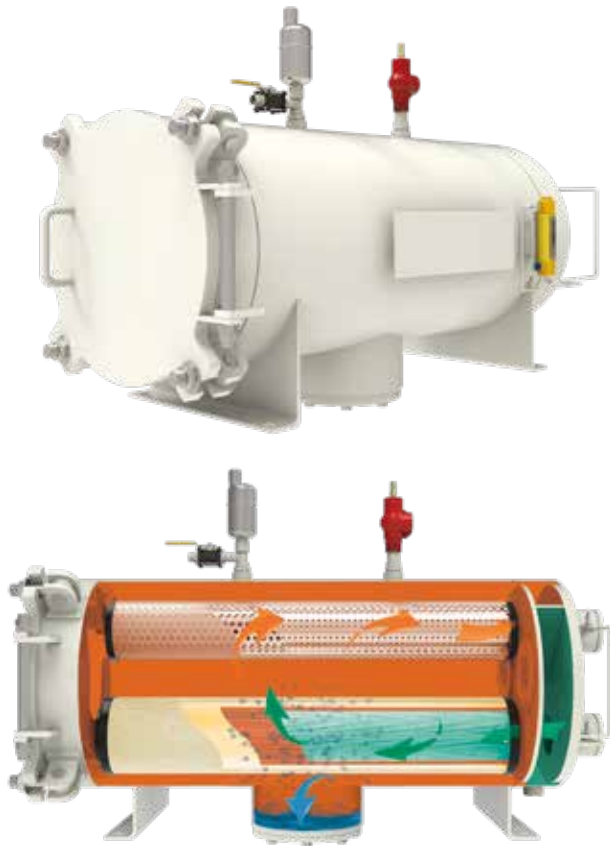

Category M Coalescer Separator housings are for Military F24, JP-8 or JP-5 fuel. Type S qualification can be used for mobile applications where minimum amounts of water and dirt in the product are expected. Facet HCS Series Horizontal Coalescer Separator housings fully comply with EI 1581, Category M, Type S requirements.

#### Reliable Performance

Facet coalescer separators are a result of 80 years of continuous research and development to meet the ever demanding performance requirements in the aviation fuel handling industry. This, along with proven field performance, demonstrates Facet's ability to provide quality products that meet current specifications as well as specific customer requirements for installations in refineries, bulk storage, terminals, heliports, airports, etc.

#### Standard Housing Design

- EI 1596 Design & Construction
- Welded carbon steel construction—other materials available on request
- ASME Code, Section VIII construction, stamped and certified
- Design pressure: 150 psi @ 250 °F (10.3 bar @ 121 °C) — other design pressures available on request
- Inlet, outlet and drain connections permanently marked
- Interior: Epoxy coated (EI 1541)
- Exterior: Prime coated
- Swing bolt head closures
- Hinged end opening cover
- Victaulic inlet and outlet connections
- Buna-N o-ring closure seal
- Choice of rod or screw base coalescer cartridge mounting styles
- Knife edge cartridge mounting seals
- 4" inlet/outlet cleanout/inspection connections (when permitted by design)
- Spider plate attached to vessel wall

#### Options

- Water defense system\*
- Automatic air eliminator\* with check valve
- Pressure relief valve\*
- Differential pressure gauge\*
- Pilot control valve
- Blind cover for pilot control mounting flange
- Sampling probes\*

(\* Mandatory for EI 1596)

# HCS Series (End Opening)

## Horizontal Coalescer Separators for Mobile Equipment

### EI 1581, 7th Edition, Category M, Type S

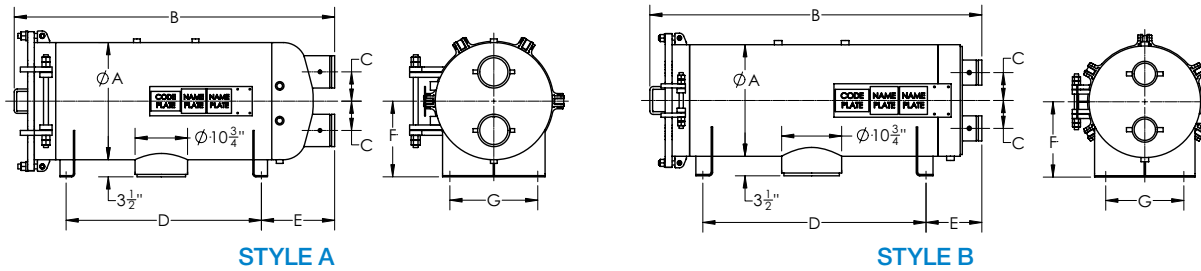

#### DATA

MODEL NUMBER <sup>(1)</sup>	FLOW RATE		REQUIRED CARTRIDGES				HOUSING LIQUID VOLUME		HOUSING DRY WEIGHT		HOUSING TYPE
	AVIATION FUEL EI 1581 CAT. M, TYPE S		COALESCER		SEPARATOR						
	gpm	lpm	qty	Model	qty	Model	gal	ltr	lbs	kg	
HCS-322-1424	157	594	3	CM-22SB-5	1	SM-424FB-5	27	102	350	159	Style B - Flat
HCS-333-1436	243	920	3	CM-33SB-5	1	SM-436FB-5	33	125	375	170	Style B - Flat
HCS-438-138	317	1200	4	CM-38SB-5	1	SM-38FF-5	73	276	700	318	Style B - Flat
HCS-456-229	475	1798	4	CM-56SB-5	2	SM-29FB-5	127	481	900	408	Style A - Dished
HCS-556-236	601	2275	5	CM-56SB-5	2	SM-36FF-5	150	568	1125	510	Style A - Dished

Other sizes available on request

#### DIMENSIONS

MODEL NUMBER <sup>(1)</sup>	INLET/OUTLET DIAMETER		DIMENSIONS <sup>(2)</sup>													
			A		B		C		D		E		F		G	
	in	mm	in	mm	in	mm	in	mm	in	mm	in	mm	in	mm	in	mm
HCS-322-1424	3	76	16	406	39 <sup>3</sup> / <sub>4</sub>	1010	5	127	21	533	9 <sup>3</sup> / <sub>4</sub>	248	11 <sup>1</sup> / <sub>2</sub>	292	11	279
HCS-333-1436	3	76	16	406	50 <sup>1</sup> / <sub>2</sub>	1283	5	127	28	711	10 <sup>3</sup> / <sub>4</sub>	273	11 <sup>1</sup> / <sub>2</sub>	292	11	279
HCS-438-138	3	76	22	559	57 <sup>1</sup> / <sub>4</sub>	1454	6	152	34	864	10 <sup>3</sup> / <sub>4</sub>	273	14 <sup>1</sup> / <sub>2</sub>	368	16	406
HCS-456-229	4	102	24	610	77 <sup>1</sup> / <sub>2</sub>	1969	6	152	52	1321	15	381	15 <sup>1</sup> / <sub>2</sub>	394	18	457
HCS-556-236	6	152	26	660	77 <sup>1</sup> / <sub>2</sub>	1969	7	178	52	1321	15	381	16 <sup>1</sup> / <sub>2</sub>	419	19	483

#### REFERENCE NOTES:

- (1) Model numbers include housing and required cartridge mounting.  
 (2) Dimensions are approximate and should not be used for installation purposes.

#### NOTES:

- a. All elements are mounted against knife edge seals.  
 b. Nameplate to be stamped with EI classified data.  
 c. Inlet chamber to be hydrostatic tested at 115 psi (7.9 bar).  
 d. Coalescer cartridges are offered with a choice of rod or screw base mounting. The suffix "SB" will be added to the coalescer model number when screw base is required.  
 Example: CM-33-5 = Rod Mount / CM-33SB-5 = Screw Base

## Horizontal Coalescer Separators for Mobile Equipment EI 1581, 7th Edition, Category C, Type S-LW

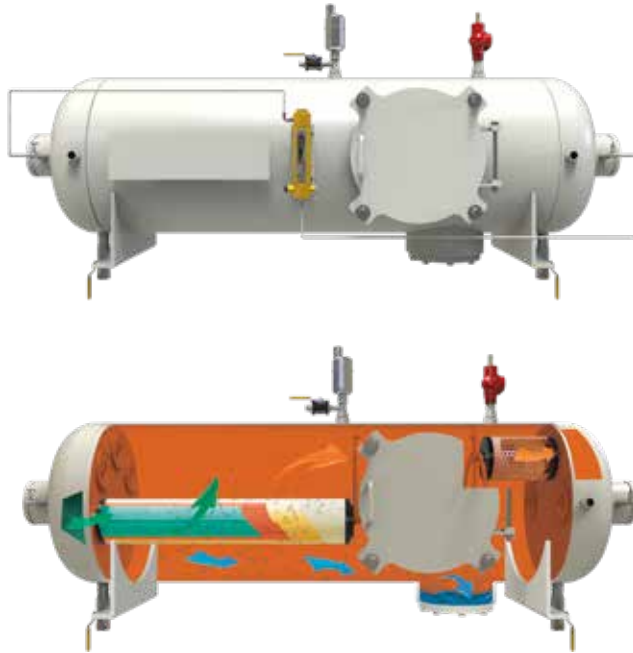

Category C Coalescer Separator housings are for commercial aviation fuel. Type S-LW qualifications can be used for mobile applications where minimum amounts of water and dirt in the product are expected. Facet HCS-M (side open) Series Horizontal Coalescer Separator housings fully comply with EI 1581, Category C, Type S-LW requirements.

### Reliable Performance

Facet coalescer separators are a result of 80 years of continuous research and development to meet the ever demanding performance requirements in the aviation fuel handling industry. This, along with proven field performance, demonstrates Facet's ability to provide quality products that meet current specifications as well as specific customer requirements for installations in refineries, bulk storage, terminals, heliports, airports, etc.

### Standard Housing Design

- EI 1596 Design & Construction
- Welded carbon steel construction—other materials available on request
- ASME Code, Section VIII construction, stamped and certified
- Design pressure: 150 psi @ 250 °F (10.3 bar @ 121 °C) — other design pressures available on request
- Inlet, outlet and drain connections permanently marked
- Interior: Epoxy coated (EI 1541)
- Exterior: Prime coated
- Swing bolt head closures
- Hinged Manway
- Victaulic inlet and outlet connections
- Buna-N o-ring closure seal
- Choice of rod or screw base coalescer cartridge mounting styles
- Knife edge cartridge mounting seals
- 4" inlet/outlet cleanout/inspection connections (when permitted by design)
- Spider plate attached to vessel wall

### Options

- Water defense system\*
- Automatic air eliminator\* with check valve
- Pressure relief valve\*
- Differential pressure gauge\*
- Pilot control valve
- Blind cover for pilot control mounting flange
- Sampling probes\*

(\* Mandatory for EI 1596)

HCS-M Series (Side Opening)  
 Horizontal Coalescer Separators for Mobile Equipment  
 EI 1581, 7th Edition, Category C, Type S-LW

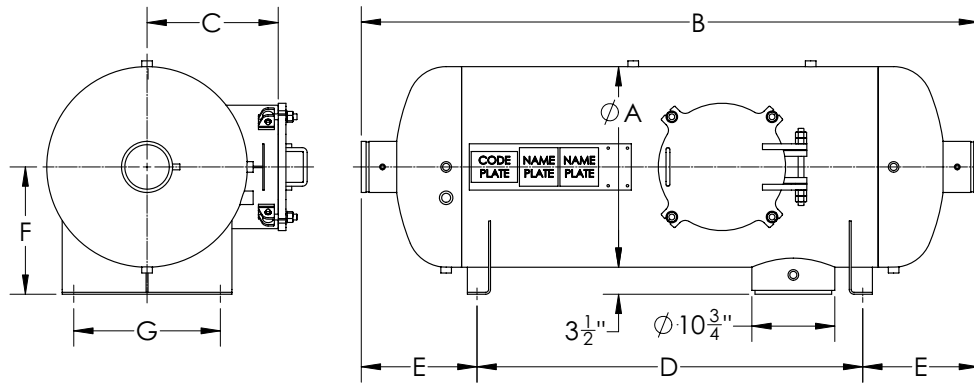

DATA

MODEL NUMBER <sup>(1)</sup>	FLOW RATE		REQUIRED CARTRIDGES				HOUSING LIQUID VOLUME		HOUSING DRY WEIGHT		HOUSING TYPE
	AVIATION FUEL EI1581 CAT. C, TYPE S-LW		COALESCER		SEPARATOR		gal	ltr	lbs	kg	
	gpm	lpm	qty	Model	qty	Model					
HCS-M-428-39	320	1211	4	CAA28-5SB	3	SS609FF-5	70	265	575	261	Dished
HCS-M-528-39	400	1514	5	CAA28-5SB	3	SS609FF-5	90	341	625	283	Dished
HCS-M-633-49	533	2018	6	CAA33-5SB	4	SS609FF-5	115	435	725	329	Dished
HCS-M-733-59	667	2525	7	CAA33-5SB	5	SS609FF-5	140	530	800	363	Dished
HCS-M-1028-69	800	3028	10	CAA28-5SB	6	SS609FF-5	150	568	850	386	Dished
HCS-M-1233-89	1050	3975	12	CAA33-5SB	8	SS609FF-5	220	833	1025	465	Dished

Other sizes available on request

DIMENSIONS

MODEL NUMBER <sup>(1)</sup>	INLET/OUTLET DIAMETER		DIMENSIONS <sup>(2)</sup>													
			A		B		C		D		E		F		G	
	in	mm	in	mm	in	mm	in	mm	in	mm	in	mm	in	mm	in	mm
HCS-M-428-39	4	102	18	457	76	1930	13	330	50	1270	13	330	12½	318	12	305
HCS-M-528-39	4	102	20	508	77	1956	14	356	50	1270	13½	343	13½	343	14	356
HCS-M-633-49	6	152	22	559	83	2108	15	381	55	1397	14	356	14½	368	16	406
HCS-M-733-59	6	152	24	610	84	2134	16	406	55	1397	14½	368	15½	394	18	457
HCS-M-1028-69	6	152	26	660	80	2032	17	432	50	1270	15	381	16½	419	19	483
HCS-M-1233-89	6	152	30	762	87	2210	19	483	55	1397	16	406	18½	470	23	584

REFERENCE NOTES:

- (1) Model numbers include housing and required cartridge mounting.  
 (2) Dimensions are approximate and should not be used for installation purposes.

NOTES:

- a. All elements are mounted against knife edge seals.  
 b. Nameplate to be stamped with EI classified data.  
 c. Inlet chamber to be hydrostatic tested at 115 psi (7.9 bar).



Facet's standard carbon steel VCS Series SuperFlex<sup>™</sup> Coalescer Separators are small, economical housings for in-line removal of water and solids from aviation fuels where water content is a problem. Using Facet high quality coalescer and separator cartridges, they provide the best water and solids removal.

#### Reliable Performance

Facet coalescer separators are a result of 80 years of continuous research and development to meet the ever demanding performance requirements in the aviation fuel handling industry. This, along with proven field performance, demonstrates Facet's ability to provide quality products that meet current specifications as well as specific customer requirements for installations in refineries, bulk storage, terminals, heliports, airports, etc.

#### Standard Housing Design

- Welded carbon steel construction—other materials available on request
- ASME Code, Section VIII construction, stamped and certified
- Design pressure: 250 psi @ 250 °F (17.2 bar @ 121 °C)
- Main closure: Blind Flange
- Head gasket: Buna-N —other materials available on request
- Vent connection: 3/4" NPT
- Drain connection: 3/4" 3000# NPT
- Inlet and outlet connections: 2" 3000# NPT
- Differential pressure gauge connection: 1/8" NPT
- Interior: Epoxy coated (EI 1541)
- Exterior: Prime coated

#### Options

- Air eliminator
- Air eliminator check valve
- Manual drain valve
- Pressure gauge assembly
- Pressure relief valve
- Sampling probes
- Adjustable support stand

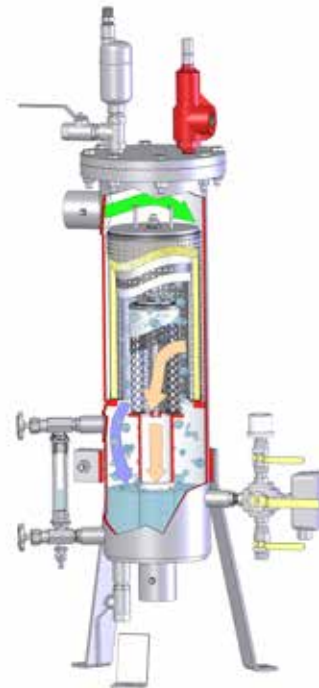

# Vertical SuperFlex™ Coalescer Separator

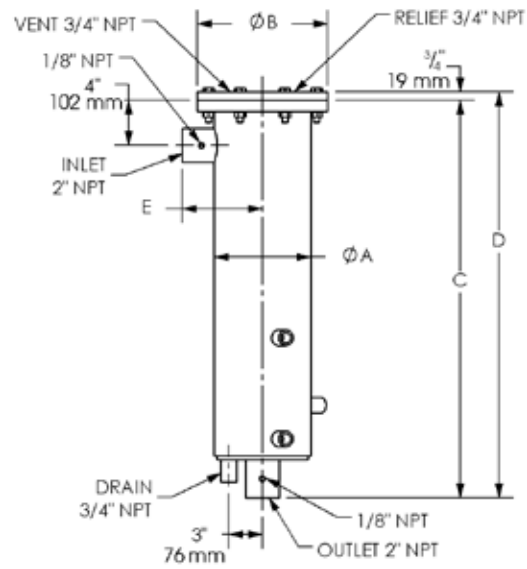

## DATA

MODEL NUMBER	INLET/OUTLET DIAMETER		DIMENSIONS										WEIGHT		LIQUID VOLUME	
			A		B		C		D		E					
	in	mm	in	mm	in	mm	in	mm	in	mm	in	mm	lbs	kg	gal	ltr
VCS-123-7-1S412FC	2	51	8 <sup>5</sup> / <sub>8</sub>	219	11 <sup>1</sup> / <sub>8</sub>	295	35 <sup>3</sup> / <sub>8</sub>	899	36 <sup>1</sup> / <sub>8</sub>	918	7 <sup>1</sup> / <sub>8</sub>	181	100	45	7	26
VCS-223-7-1S422FC	2	51	8 <sup>5</sup> / <sub>8</sub>	219	11 <sup>1</sup> / <sub>8</sub>	295	49 <sup>7</sup> / <sub>8</sub>	1267	50 <sup>5</sup> / <sub>8</sub>	1286	7 <sup>1</sup> / <sub>8</sub>	181	125	56	10	38
VCS-323-7-1S432FC	2	51	8 <sup>5</sup> / <sub>8</sub>	219	11 <sup>1</sup> / <sub>8</sub>	295	63 <sup>5</sup> / <sub>8</sub>	1622	64 <sup>5</sup> / <sub>8</sub>	1641	7 <sup>1</sup> / <sub>8</sub>	181	150	68	13	49



CC-23-7 Coalescer



SS412FC Separator

### Standard Design Features

- Provides two-stage coalescing and separation
- Recommended maximum operating temperature: 240 °F (115 °C)
- Maximum differential pressure: 75 psi (5.17 bar)
- pH range from 5 to 9
- Flow direction: Outside to in
- All metal components coated to protect against corrosion
- Standard gaskets are Buna-N—other materials available on request

### DIMENSIONS

MODEL NUMBER	OD		ID		LENGTH		WEIGHT	
	in	mm	in	mm	in	mm	lbs	kg
<b>COALESCER</b>								
CC-23-7	7 <sup>5</sup> / <sub>8</sub>	194	5 <sup>5</sup> / <sub>8</sub>	143	13 <sup>1</sup> / <sub>16</sub>	348	4	1.8
CC-23-7X2	7 <sup>5</sup> / <sub>8</sub>	194	5 <sup>5</sup> / <sub>8</sub>	143	27 <sup>1</sup> / <sub>2</sub>	698	8	3.6
CC-23-7X3	7 <sup>5</sup> / <sub>8</sub>	194	5 <sup>5</sup> / <sub>8</sub>	143	41 <sup>1</sup> / <sub>4</sub>	1048	12	5.4
<b>SEPARATOR</b>								
SS412FC	4 <sup>1</sup> / <sub>8</sub>	105	1 <sup>7</sup> / <sub>8</sub>	48	11 <sup>1</sup> / <sub>2</sub>	292	3	1.4
SS422FC	4 <sup>1</sup> / <sub>8</sub>	105	1 <sup>7</sup> / <sub>8</sub>	48	21 <sup>1</sup> / <sub>2</sub>	546	6	2.7
SS432FC	4 <sup>1</sup> / <sub>8</sub>	105	1 <sup>7</sup> / <sub>8</sub>	48	31 <sup>1</sup> / <sub>2</sub>	800	9	4.1

### FLOW RATES & ELEMENT MODELS

MODEL NUMBER	QTY	ELEMENTS		KEROSENE		AVIATION FUEL <sup>(1)</sup>		GASOLINE		DIESEL		
		COALESCER	QTY	SEPARATOR	gpm	lpm	gpm	lpm	gpm	lpm	gpm	lpm
VCS-123-7-1S412FC	1	CC-23-7	1	SS412FC	37	140	25	94	55	208	27	102
VCS-223-7-1S422FC	1	CC-23-7X2	1	SS422FC	75	284	50	189	100	378	42	159
VCS-323-7-1S432FC	1	CC-23-7X3	1	SS432FC	112	424	75	284	168	636	68	257

1) Tested to meet the effluent requirements of EI 1581, 7th Edition, Category C & M, Type S-LW (Jet Fuel and AV-Gas).



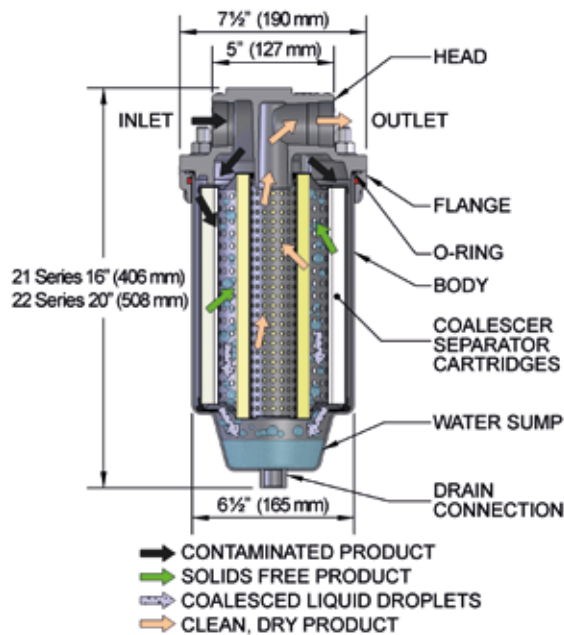

**Differential Pressure Indicator -**  
The piston-type differential pressure indicator provides a simple visual warning. When 15 psi (1.03 bar) differential pressure is reached, the gauge indicator moves from green to red zone. This warning will prevent premature cartridge change-out.

The Facet VF-21SB/22SB, when configured as a filter water separator, is an economical, compact housing designed to remove water and solids from aviation fuels.

Both interior and exterior surfaces of the carbon steel body are epoxy coated to protect against corrosion.

This sturdy, single cartridge housing is easy to maintain and requires only 2" (51 mm) base clearance for cartridge change out.

### Standard Housing Design

- Carbon steel body
- Aluminum head
- Epoxy coated internally and externally
- 150 psi (10.3 bar) design pressure
- Swing bolt quick open closure
- Buna-N o-ring closure gasket
- Vent and drain connections w/ brass petcocks provided
- 1½" NPT inlet and outlet connections

### VESSEL OPTIONS

MODEL	DESCRIPTION
VF-21SB	Housing only
VF-21SB-PG	Housing w/ Direct Reading Differential Pressure Gauge
VF-21SB-PGS	Housing w/ Direct Reading Differential Pressure Gauge & Sight Glass (not for Avgas 100 LL)
VF-21SB-PGWP	Housing w/ Direct Reading Differential Pressure Gauge & ¾" NPT Coupling for Water Probe
VF-21SB-S	Housing w/ Sight Glass (not for Avgas 100 LL)
VF-21SB-WP	Housing w/ ¾" NPT Coupling for Water Probe
VF-21SB-PG2	Housing with 1/8" NPT thread connection to accommodate an external differential pressure gauge (supplied by others)
VF-22SB	Housing only
VF-22SB-PG	Housing w/ Direct Reading Differential Pressure Gauge
VF-22SB-PGS	Housing w/ Direct Reading Differential Pressure Gauge & Sight Glass (not for Avgas 100 LL)
VF-22SB-PGWP	Housing w/ Direct Reading Differential Pressure Gauge & ¾" NPT Coupling for Water Probe
VF-22SB-S	Housing w/ Sight Glass (not for Avgas 100 LL)
VF-22SB-WP	Housing w/ ¾" NPT Coupling for Water Probe
VF-22SB-PG2	Housing with 1/8" NPT connection to accommodate an external differential pressure gauge (supplied by others)
VF-22SB-PG2WP	Housing w/ 1/8" NPT thread to accept compatible Gammon or Schultz DP Pressure Gauge & ¾" NPT Coupling for Water Probe
644160	Mounting Bracket
644964	Grounding Cable
606521	Closure O-Ring

**Water Sight Glass -** The water sight glass provides an easy means to detect water in the sump. The weighted ball, visible in the sight glass, will float only when water is present. The floating ball is an indication water should be drained from the housing to prevent both cartridge contamination and water traveling downstream from the housing. Not for Avgas 100 LL.

ACCORDING TO THE REQUIREMENTS OF EUROPEAN PRESSURE EQUIPMENT DIRECTIVE (PED) 2014/68/EU ART. 4.3, WITHIN THE OPERATING LIMITS PROVIDED ON VESSEL NAMEPLATE AND SUMMARIZED BELOW, THESE FILTERS ARE DESIGNED AND MANUFACTURED IN ACCORDANCE WITH THE SOUND ENGINEERING PRACTICE AND EXEMPT FROM CE MARKING AND CERTIFICATION: 10 BAR(G) @ 35°C FOR AV-GAS AND JET FUEL.

# Fuel-Gard® VF-21SB/22SB Filter Water Separator

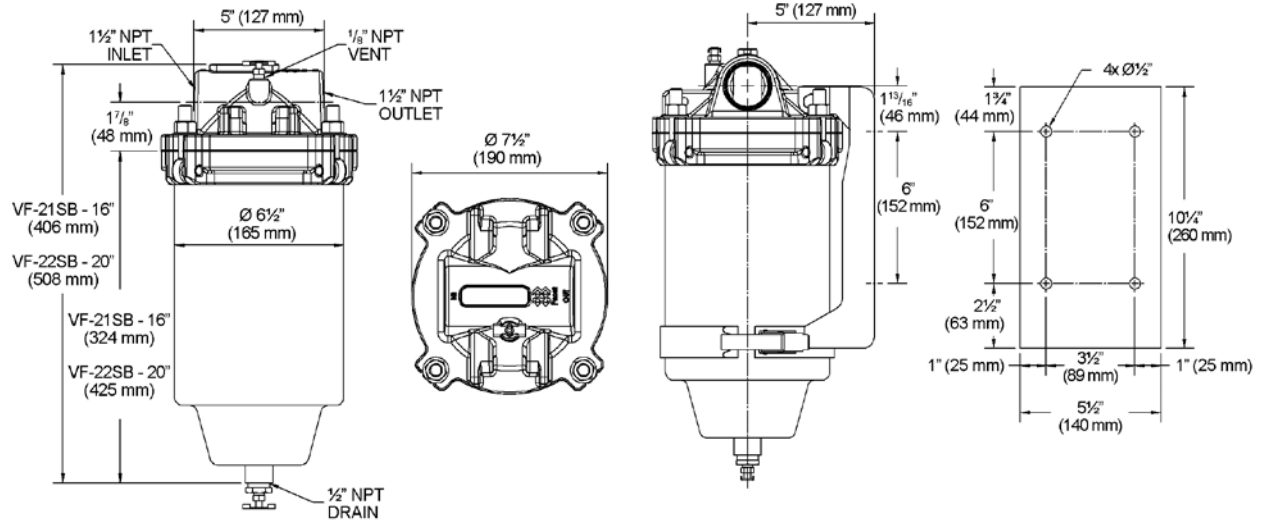

**Optional Mounting Bracket**



The purpose of this bonding kit is to lessen the potential for static charge build up in the metal body of these vessels. This kit will allow the bowl, previously isolated because of the epoxy powder coating, to be bonded to system piping. One end of the bonding wire consists of a clamp that tightens onto the 1-1/2" piping. The other end has a heavy duty spring clamp that can be attached to the drain line valve. Remember if placing either end on a painted surface to scratch down to bare metal to allow contact.

This kit, part # 644964 can be purchased separately for existing vessels.







Facet VF-21SB/22SB Series coalescer separator cartridges provide long service life and high solids holding capacity with no unloading characteristics. These filter separator cartridges effectively remove water and solids from fuels.

### Standard Design Features

- Recommended maximum operating temperature: 240 °F (115 °C)
- Maximum differential pressure: 75 psi (5.17 bar)
- Fluid pH range: 5 to 9
- Flow Direction: Outside to In

### Materials

- Carbon steel structural components
- All metal components coated to protect against corrosion
- Standard gaskets are Buna-N—other materials available upon request

MODEL NUMBER	ELEMENTS	KEROSENE		AVIATION FUEL <sup>(1)</sup>		GASOLINE		DIESEL	
		gpm	lpm	gpm	lpm	gpm	lpm	gpm	lpm
VF-21SB	CC-21-7	35	132	15	57	45	170	23	87
VF-22SB	CC-22-7	50	189	21.2	80	60	227	30	114

1) Tested to meet the effluent requirements of EI 1581, 7th Edition, Category C & M, Type S-LW (Jet Fuel and AV-Gas).

\* For applications other than AV-Gas and Jet Fuel, please contact the nearest Facet office.

\*\*DP given for viscosity <2 cSt



## Portable Fuel Filtration and Pumping Set for Helicopters and Light Aircrafts



The Facet portable filtration and pumping set is an economical, light and compact packaged unit for the supply of clean, dry fuel to helicopters and light aircraft.

The standard unit is fitted with a Facet model VF-21/22-SB, filter separator or monitor, differential pressure gauge and a 12 volt or 24 volt electric pump for a maximum flow of 11 gpm (42 lpm). The unit is complete with intake and delivery hoses and comes with a lightweight antidrip nozzle.

The unit can be run from a vehicle battery or from the helicopter's own power supply.

A filter monitor can be fitted as an alternative to the standard filter water separator.

Quality fuel accessories are available as options to improve and expand your transfer fuel systems for greater convenience and higher accuracies.

### Standard Package Design

- Facet Model VF-21/22-SB filter separator or monitor
- Differential pressure gauge
- 13' (4 metre) fuel intake hose, with nipples for coupling to the pump and fuel intake filter
- 13' (4 metre) discharge hose, with nipples for coupling to the pump and antidrip nozzle
- High-flow automatic nozzle
- Electric pump, flow rate 11 gpm (42 lpm)
- On/Off switch
- Electric supply cable with nippers for connection to the power supply
- Ground connection cable
- Tubular type chassis for light weight and portability
- Approximate weight: 66 lbs (30 kgs)
- Chassis Dimensions:  
17¾" x 19¾" x 20" (450 mm x 501 mm x 508 mm)

### Options

- Volumetric meter
- 230 VAC pump
- Hose reel





### For Maximum Water Coalescing Efficiency and Solids Holding Capacity

Facet CAA Series 5 coalescer cartridges offer the finest performance available. This standard line of high flow coalescer cartridges removes ultra-fine solids and enhances separation of water from aviation fuel.

The Facet coalescer separator housings equipped with CAA Series 5 coalescer and companion separator cartridges have been tested and fully qualified to meet the performance requirements to EI 1581, 7th Edition, Category C.

Built for balanced fluid flow-thru and structural strength, each CAA Series 5 coalescer cartridge is a single-piece construction of various combined media, precisely arranged in many layers and pleats, wrapped around a coated, perforated metal center tube—all encased in an outer sock material. All are 6" OD (152 mm) by 3½" ID (89 mm) and available in standard interchangeable nominal lengths from 11¼" (290 mm) to 57¼" (1450 mm).

The CAA Series 5 coalescer cartridges are available in two cartridge mounting styles: self-centering rod mount and screw base. The rod mount style has treated metal end caps, while the screw base ends are injection molded, glass-filled nylon. This screw base material offers superior strength and ease of maintenance—uniform threads, no shrinkage, no galling and no gasket to recover.

A permanently affixed Buna-N gasket seals against the V-type knife edge mounting adaptor to provide a positive seal. It will not separate from the cartridge during installation or change out.

### Standard Design Features

- Qualified to the 7th Edition of EI 1581, Category C
- Multi-layered media for increased solids holding capacity
- Ultra-fine solids removal
- Maximum water coalescence
- Balanced cartridge flow characteristics
- Recommended maximum operating temperature: 240 °F (115 °C)
- Withstands in excess of 75 psi (5.17 bar) differential pressure
- pH range from 5 to 9
- Screw base or open-end configuration

### Materials

- All metal components are treated against corrosion
- Screw base ends are injection molded, glass-filled nylon with locked-in gaskets
- Buna-N gaskets—other materials are available on request

CAA Series 5  
Coalescer Cartridges  
Qualified to EI 1581, 7th Edition, Category C

DATA

MODEL NUMBER	NOMINAL LENGTH		OUTSIDE DIAMETER		INSIDE DIAMETER		MOUNTING STYLE
	in	mm	in	mm	in	mm	
CAA11-5	11¼	290	6	152	3½	89	Rod
CAA14-5	14½	370	6	152	3½	89	Rod
CAA14-5SB	15	380	6	152	3½	89	Screw Base
CAA22-5	22¼	560	6	152	3½	89	Rod
CAA22-5SB	23	580	6	152	3½	89	Screw Base
CAA28-5	28¾	730	6	152	3½	89	Rod
CAA28-5SB	29	740	6	152	3½	89	Screw Base
CAA33-5	33¼	840	6	152	3½	89	Rod
CAA33-5SB	34	860	6	152	3½	89	Screw Base
CAA38-5	38	960	6	152	3½	89	Rod
CAA38-5SB	39	990	6	152	3½	89	Screw Base
CAA43-5	43¼	1100	6	152	3½	89	Rod
CAA43-5SB	45	1140	6	152	3½	89	Screw Base
CAA56-5	56¼	1430	6	152	3½	89	Rod
CAA56-5SB	57	1450	6	152	3½	89	Screw Base

NOTE: The Facet screw base adaptor part number is 677453A-AM

## SS-5 and ST-5 Series Separator Cartridges Qualified to EI 1581, 7th Edition, Category C



Synthetic Series

Teflon<sup>®</sup> Series

Facet SS-5 Series Synthetic and ST-5 Series Teflon<sup>®</sup> separator cartridges are cleanable and reusable. They come in a variety of dimensional and end cap configurations.

Facet's SS-5 Series Synthetic separator cartridges feature a specially developed treated hydrophobic media. This media provides improved separation of fine water drops compared to standard Teflon<sup>®</sup> screen. An ultrasonically seamed tube of the synthetic screen is placed around an epoxy coated metal shell, then adhesive bonded to metal end caps with gaskets.

Facet's ST-5 Series Teflon<sup>®</sup> separators use Teflon<sup>®</sup> coated screen wrapped around an epoxy coated metal shell, lock-seam folded, then adhesive bonded to metal end caps with gaskets.

Both Facet SS-5 and ST-5 Series Synthetic separators have the distinctive Facet Velocigard which provides balanced flow of product throughout the cartridge. All metal components are treated to resist corrosion.

Maximum recommended operation temperature is 240 °F (115 °C). For compatibility in extreme operating conditions, other gasket, adhesive and metal materials are available.

### Standard Design Features

- Cleanable and reusable
- Superior water barrier
- Recommended maximum operating temperature: 240 °F (115 °C)
- pH range from 5 to 9
- Designed for balanced flow through cartridge
- Flow direction: Outside to in

### Materials

- Synthetic mesh or Teflon<sup>®</sup> coated screen
- Treated metal components for corrosion protection
- Buna-N gaskets
- Other gasket, adhesive and metal materials are available on request

SS-5 and ST-5 Series  
 Separator Cartridges  
 Qualified to EI 1581, 7th Edition, Category C

DATA

MODEL NUMBER SYNTHETIC	MODEL NUMBER TEFLON	NOMINAL LENGTH		OUTSIDE DIAMETER		INSIDE DIAMETER SEALING END		INSIDE DIAMETER MOUNTING END	
		in	mm	in	mm	in	mm	in	mm
SS318FA-5	ST318FA-5	18	460	3	76	BLIND	13	2	51
SS324FA-5	ST324FA-5	24	610	3	76	BLIND	13	2	51
SS412FC-5	ST412FC-5	11½	290	4⅞	105	1⅞	48	1⅞	48
SS415FB-5	ST415FB-5	15	380	4½	114	BLIND	13	3½	89
SS417FB-5	ST417FB-5	17	430	4½	114	BLIND	13	3½	89
SS422FC-5	ST422FC-5	22½	570	4⅞	105	1⅞	48	1⅞	48
SS424FB-5	ST424FB-5	24	610	4½	114	BLIND	13	3½	89
SS430FB-5	ST430FB-5	30	760	4½	114	BLIND	13	3½	89
SS432FC-5	ST432FC-5	31½	800	4⅞	105	1⅞	48	1⅞	48
SS436FB-5	ST436FB-5	36	910	4½	114	BLIND	13	3½	89
SS609FB-5	ST609FB-5	9	230	6	152	BLIND	13	3½	89
SS609FF-5	ST609FF-5	9	230	6	152	BLIND	13	4½	114
SS611FD-5	ST611FD-5	11¼	290	6	152	3½	89	3½	89
SS612FB-5	ST612FB-5	12⅞	310	6	152	BLIND	13	3½	89
SS614FD-5	ST614FD-5	14½	370	6	152	3½	89	3½	89
SS616FD-5	ST616FD-5	16¼	410	6	152	3½	89	3½	89
SS618FB-5	ST618FB-5	18	460	6	152	BLIND	13	3½	89
SS622FD-5	ST622FD-5	22¼	560	6	152	3½	89	3½	89
SS624FB-5	ST624FB-5	24	610	6	152	BLIND	13	3½	89
SS624FE-5	ST624FE-5	24	610	6	152	BLIND	13	4⅞	105
SS624FF-5	ST624FF-5	24	610	6	152	BLIND	13	4½	114
SS629FD-5	ST629FD-5	28¾	730	6	152	3½	89	3½	89
SS630FB-5	ST630FB-5	30	760	6	152	BLIND	13	3½	89
SS630FD-5	ST630FD-5	30	760	6	152	3½	89	3½	89
SS630FE-5	ST630FE-5	30	760	6	152	BLIND	13	4⅞	105
SS630FF-5	ST630FF-5	30	760	6	152	BLIND	13	4½	114
SS633FB-5	ST633FB-5	33¼	840	6	152	BLIND	13	3½	89
SS633FD-5	ST633FD-5	33¼	840	6	152	3½	89	3½	89
SS636FB-5	ST636FB-5	36	910	6	152	BLIND	13	3½	89
SS636FD-5	ST636FD-5	36	910	6	152	3½	89	3½	89
SS636FE-5	ST636FE-5	36	910	6	152	BLIND	13	4⅞	105
SS636FF-5	ST636FF-5	36	910	6	152	BLIND	13	4½	114
SS638FD-5	ST638FD-5	38	965	6	152	3½	89	3½	89
SS640FD-5	ST640FD-5	40	1020	6	152	3½	89	3½	89
SS640FE-5	ST640FE-5	40	1020	6	152	BLIND	13	4⅞	105
SS640FF-5	ST640FF-5	40	1020	6	152	BLIND	13	4½	114
SS643FB-5	ST643FB-5	43	1090	6	152	BLIND	13	3½	89
SS643FD-5	ST643FD-5	43	1090	6	152	3½	89	3½	89
SS643FF-5	ST643FF-5	43	1090	6	152	BLIND	13	4½	114
SS644FB-5	ST644FB-5	44	1120	6	152	BLIND	13	3½	89
SS644FD-5	ST644FD-5	44	1120	6	152	3½	89	3½	89
SS644FE-5	ST644FE-5	44	1120	6	152	BLIND	13	4⅞	105
SS644FF-5	ST644FF-5	44	1120	6	152	BLIND	13	4½	114
SS648FD-5	ST648FD-5	48	1220	6	152	3½	89	3½	89
SS648FF-5	ST648FF-5	48	1220	6	152	BLIND	13	4½	114
SS656FB-5	ST656FB-5	56	1420	6	152	BLIND	13	3½	89
SS656FF-5	ST656FF-5	56	1420	6	152	BLIND	13	4½	114



#### For Maximum Water Coalescing Efficiency And Solids Holding Capacity

Facet CM Series coalescer cartridges offer the finest performance available. This line of high flow coalescer cartridges removes ultra-fine solids and enhances separation of water from aviation fuel.

The Facet coalescer separator housings equipped with CM Series coalescer and companion separator cartridges have been tested and fully qualified to EI 1581, 7th Edition, for category "M", in both vertical and horizontal orientations.

Built for balanced fluid flow-thru and structural strength, each CM Series coalescer cartridge is a single piece construction of various combined media, precisely arranged in many layers and pleats, wrapped around a coated, perforated metal center tube- all encased in an outer sock material. All are 6" OD (152 mm) by 3½" ID (89 mm) and available in standard interchangeable nominal lengths in increments from 11¼" (290 mm) to 57¼" (1450 mm).

The CM Series 6 coalescer cartridges are available in two cartridge mounting styles; self-centering rod mount and screw base. The rod mount style has treated metal end caps, while the screw base ends are injection molded, glass-filled nylon. This screw base material offers superior strength and ease of maintenance -uniform threads, no shrinkage, no galling and no gasket to recover.

A permanently affixed Buna gasket seals against the V-type knife edge mounting adaptor to provide a positive seal. It will not separate from the cartridge during installation or change out.

#### Standard Design Features

- Qualified to the 7th Edition of EI 1581 for all category "M"
- Multi-layered media for increased solids holding capacity
- Ultra-fine solids removal
- Maximum water coalescence
- Balanced cartridge flow characteristics
- Recommended maximum operating temperature: 240 °F (115 °C)
- Withstands excess of 75 psi (5.17 bar) differential pressure
- pH range from 5 to 9
- Choice of self-centering rod or screw base coalescer cartridge mounting styles

#### Materials

- All metal components are treated against corrosion
- Screw base ends are injection molded, glass-filled nylon with locked-in gaskets
- Buna-N gaskets-other materials are available upon request

CM Series  
 Coalescer Cartridges  
 Qualified to EI 1581, 7th Edition, Category M

**DATA**

MODEL NUMBER	NOMINAL LENGTH		OUTSIDE DIAMETER		INSIDE DIAMETER		MOUNTING STYLE
	in	mm	in	mm	in	mm	
CM-11-5	11¼	290	6	152	3½	89	Rod
CM-14-5	14½	370	6	152	3½	89	Rod
CM-14SB-5	15	380	6	152	3½	89	Screw Base
CM-22-5	22¼	560	6	152	3½	89	Rod
CM-22SB-5	23	580	6	152	3½	89	Screw Base
CM-28-5	28¾	730	6	152	3½	89	Rod
CM-28SB-5	29	740	6	152	3½	89	Screw Base
CM-33-5	33¼	840	6	152	3½	89	Rod
CM-33SB-5	34	860	6	152	3½	89	Screw Base
CM-38-5	38	960	6	152	3½	89	Rod
CM-38SB-5	39	990	6	152	3½	89	Screw Base
CM-43-5	43¼	1100	6	152	3½	89	Rod
CM-43SB-5	45	1140	6	152	3½	89	Screw Base
CM-56-5	56¼	1430	6	152	3½	89	Rod
CM-56SB-5	57	1450	6	152	3½	89	Screw Base

NOTE: The Facet screw base adaptor part number is 677453A-AM



### 5th Edition DOD Coalescer Cartridge

Facet's CM Series Coalescer cartridge offer the finest performance available in aviation fuel filtration for the United States Armed Forces.

This line of high flow coalescer cartridges removes ultra fine solids and enhances the optimum separation of water from Military Jet Fuel.

### Applications

Facet's CM Series elements have been tested and fully qualified to meet API/IP 1581, 5th Edition, M category, Type S in both the single stage (DOD Style) and two Stage (API style) configuration.

Designed specifically for the US Military, these high performance coalescers flow at a rate of 1 gallon per minute per linear inch and directly replace the following:

- NSN 4330-01-407-3548 40" length
- NSN 4330-00-983-0998 20" length

### Benefits

- Direct replacement without modification kit
- Quick easy cartridge change out
- May be used with DOD canister and/or API Style Separator
- Removes ultra fine particulate
- Provide optimum water removal
- Multi layered media for increased solids holding capacity

### Standard Design Features

- Maximum pressure rating: 75PSI
- Maximum operating temperature: 240°F
- End Caps: Top – Blind End  
Bottom – Mounting End w/O-Ring Seal
- Flow Direction: Inside/Out

MODEL NUMBER	NSN NUMBER	NOMINAL LENGTH		OUTSIDE DIAMETER		INSIDE DIAMETER	
		in	mm	in	mm	in	mm
CM420-5	4330-01-511-8209	20"	508	3¾	95	1⅞	30
CM440-5	4330-01-511-8268	40"	1016	3¾	95	1⅞	30





### Standard Design Features

- Cleanable and reusable
- Superior water barrier
- Recommended maximum operating temperature: 240 °F (115 °C)
- pH range from 5 to 9
- Designed for balanced flow through cartridge
- Flow direction: Outside to in

### Materials

- Synthetic mesh coated screen
- Treated metal components for corrosion protection
- Buna-N gaskets-other gasket, adhesive and metal materials are available upon request

Facet's SM Series synthetic separator cartridges feature a specially developed treated hydrophobic media. This media provides improved separation of fine water drops compared to standard Teflon screen. An ultrasonically seamed double tube of the synthetic screen is placed around an epoxy coated metal shell, then adhesive bonded to metal end caps with gaskets.

Facet SM Series separators have the distinctive Facet Velocigard which provides balanced flow of product throughout the cartridge. All metal components are treated to resist corrosion. Maximum recommended operating temperature is 240 °F (115 °C). For compatibility in extreme operating conditions, other gasket, adhesive and metal materials are available.

SM Series  
 Separator Cartridges  
 Qualified to EI 1581, 7th Edition, Category M

DATA

MODEL NUMBER	NOMINAL LENGTH		OUTSIDE DIAMETER		INSIDE DIAMETER SEALING END		INSIDE DIAMETER MOUNTING END	
	in	mm	in	mm	in	mm	in	mm
SM-318FA-5	18	460	3	76	BLIND	13	2	51
SM-324FA-5	24	610	3	76	BLIND	13	2	51
SM-412FC-5	11½	290	4¼	105	1⅞	48	1⅞	48
SM-415FB-5	15	380	4½	114	BLIND	13	3½	89
SM-417FB-5	17	430	4½	114	BLIND	13	3½	89
SM-422FC-5	22½	570	4⅞	105	1⅞	48	1⅞	48
SM-424FB-5	24	610	4½	114	BLIND	13	3½	89
SM-430FB-5	30	760	4½	114	BLIND	13	3½	89
SM-432FC-5	31½	800	4⅞	105	1⅞	48	1⅞	48
SM-436FB-5	36	910	4½	114	BLIND	13	3½	89
SM-09FB-5	9	230	6	152	BLIND	13	3½	89
SM-09FF-5	9	230	6	152	BLIND	13	4½	114
SM-11FD-5	11¼	290	6	152	3½	89	3½	89
SM-12FB-5	12⅞	310	6	152	BLIND	13	3½	89
SM-14FD-5	14½	370	6	152	3½	89	3½	89
SM-16FD-5	16¼	410	6	152	3½	89	3½	89
SM-18FB-5	18	460	6	152	BLIND	13	3½	89
SM-22FD-5	22¼	560	6	152	3½	89	3½	89
SM-24FB-5	24	610	6	152	BLIND	13	3½	89
SM-24FE-5	24	610	6	152	BLIND	13	4⅞	105
SM-24FF-5	24	610	6	152	BLIND	13	4½	114
SM-29FD-5	28¾	730	6	152	3½	89	3½	89
SM-30FB-5	30	760	6	152	BLIND	13	3½	89
SM-30FD-5	30	760	6	152	3½	89	3½	89
SM-30FE-5	30	760	6	152	BLIND	13	4⅞	105
SM-30FF-5	30	760	6	152	BLIND	13	4½	114
SM-33FB-5	33¼	840	6	152	BLIND	13	3½	89
SM-33FD-5	33¼	840	6	152	3½	89	3½	89
SM-36FB-5	36	910	6	152	BLIND	13	3½	89
SM-36FD-5	36	910	6	152	3½	89	3½	89
SM-36FE-5	36	910	6	152	BLIND	13	4⅞	105
SM-36FF-5	36	910	6	152	BLIND	13	4½	114
SM-38FD-5	38	965	6	152	3½	89	3½	89
SM-40FD-5	40	1020	6	152	3½	89	3½	89
SM-40FE-5	40	1020	6	152	BLIND	13	4⅞	105
SM-40FF-5	40	1020	6	152	BLIND	13	4½	114
SM-43FB-5	43	1090	6	152	BLIND	13	3½	89
SM-43FD-5	43	1090	6	152	3½	89	3½	89
SM-44FB-5	44	1120	6	152	BLIND	13	3½	89
SM-44FD-5	44	1120	6	152	3½	89	3½	89
SM-44FE-5	44	1120	6	152	BLIND	13	4⅞	105
SM-44FF-5	44	1120	6	152	BLIND	13	4½	114
SM-48FD-5	48	1220	6	152	3½	89	3½	89
SM-48FF-5	48	1220	6	152	BLIND	13	4½	114
SM-56FB-5	56	1420	6	152	BLIND	13	3½	89
SM-56FF-5	56	1420	6	152	BLIND	13	4½	114



### For Maximum Water Coalescing Efficiency And Solids Holding Capacity

Facet CM100 Series coalescer cartridges offer the finest performance available. This line of high flow coalescer cartridges removes ultra-fine solids and enhances separation of water from aviation fuel.

The Facet coalescer separator housings equipped with CM100 Series coalescer and companion separator cartridges have been tested and fully qualified to EI 1581, 7th Edition, for category "M100", in both vertical and horizontal orientations.

Built for balanced fluid flow-thru and structural strength, each CM100 Series coalescer cartridge is a single piece construction of various combined media, precisely arranged in many layers and pleats, wrapped around a coated, perforated metal center tube- all encased in an outer sock material. All are 6" OD (152 mm) by 3½" ID (89 mm) and available in standard interchangeable nominal lengths in increments from 11¼" (290 mm) to 57¼" (1450 mm).

The CM100 Series 5 coalescer cartridges are available in two cartridge mounting styles; self-centering rod mount and screw base. The rod mount style has treated metal end caps, while the screw base ends are injection molded, glass-filled nylon. This screw base material offers superior strength and ease of maintenance- uniform threads, no shrinkage, no galling and no gasket to recover.

A permanently affixed Buna gasket seals against the V-type knife edge mounting adaptor to provide a positive seal. It will not separate from the cartridge during installation or change out.

### Standard Design Features

- Qualified to the 7th Edition of EI 1581 for all category "M100"
- Multi-layered media for increased solids holding capacity
- Ultra-fine solids removal
- Maximum water coalescence
- Balanced cartridge flow characteristics
- Recommended maximum operating temperature: 240 °F (115 °C)
- Withstands excess of 75 psi (5.17 bar) differential pressure
- pH range from 5 to 9
- Choice of self-centering rod or screw base coalescer cartridge mounting styles

### Materials

- All metal components are treated against corrosion
- Screw base ends are injection molded, glass-filled nylon with locked-in gaskets
- Buna-N gaskets-other materials are available upon request

CM100 Series  
 Coalescer Cartridges  
 Qualified to EI 1581, 7th Edition, Category M100

**DATA**

MODEL NUMBER	NOMINAL LENGTH		OUTSIDE DIAMETER		INSIDE DIAMETER		MOUNTING STYLE
	in	mm	in	mm	in	mm	
CM100-11-5	11¼	290	6	152	3½	89	Rod
CM100-14-5	14½	370	6	152	3½	89	Rod
CM100-14SB-5	15	380	6	152	3½	89	Screw Base
CM100-22-5	22¼	560	6	152	3½	89	Rod
CM100-22SB-5	23	580	6	152	3½	89	Screw Base
CM100-28-5	28¾	730	6	152	3½	89	Rod
CM100-28SB-5	29	740	6	152	3½	89	Screw Base
CM100-33-5	33¼	840	6	152	3½	89	Rod
CM100-33SB-5	34	860	6	152	3½	89	Screw Base
CM100-38-5	38	960	6	152	3½	89	Rod
CM100-38SB-5	39	990	6	152	3½	89	Screw Base
CM100-43-5	43¼	1100	6	152	3½	89	Rod
CM100-43SB-5	45	1140	6	152	3½	89	Screw Base
CM100-56-5	56¼	1430	6	152	3½	89	Rod
CM100-56SB-5	57	1450	6	152	3½	89	Screw Base

NOTE: The Facet screw base adaptor part number is 677453A-AM.



### Standard Design Features

- Cleanable and reusable
- Superior water barrier
- Recommended maximum operating temperature: 240 °F (115 °C)
- pH range from 5 to 9
- Designed for balanced flow through cartridge
- Flow direction: Outside to in

### Materials

- Synthetic mesh coated screen
- Treated metal components for corrosion protection
- Buna-N gaskets-other gasket, adhesive and metal materials are available upon request

Facet's SM100 Series synthetic separator cartridges feature a specially developed treated hydrophobic media. This media provides improved separation of fine water drops compared to standard Teflon<sup>®</sup> screen. An ultrasonically seamed double tube of the synthetic screen is placed around an epoxy coated metal shell, then adhesive bonded to metal end caps with gaskets.

Facet SM100 Series separators have the distinctive Facet Velocigard which provides balanced flow of product throughout the cartridge. All metal components are treated to resist corrosion. Maximum recommended operating temperature is 240 °F (115 °C). For compatibility in extreme operating conditions, other gasket, adhesive and metal materials are available.

SM100 Series  
 Separator Cartridges  
 Qualified to EI 1581, 7th Edition, Category M100

**DATA**

MODEL NUMBER	NOMINAL LENGTH		OUTSIDE DIAMETER		INSIDE DIAMETER SEALING END		INSIDE DIAMETER MOUNTING END	
	in	mm	in	mm	in	mm	in	mm
SM100-318FA-5	18	460	3	76	BLIND	13	2	51
SM100-324FA-5	24	610	3	76	BLIND	13	2	51
SM100-412FC-5	11 ½	290	4 ¼	105	1 ⅞	48	1 ⅞	48
SM100-415FB-5	15	380	4 ½	114	BLIND	13	3 ½	89
SM100-417FB-5	17	430	4 ½	114	BLIND	13	3 ½	89
SM100-422FC-5	22 ½	570	4 ⅞	105	1 ⅞	48	1 ⅞	48
SM100-424FB-5	24	610	4 ½	114	BLIND	13	3 ½	89
SM100-430FB-5	30	760	4 ½	114	BLIND	13	3 ½	89
SM100-432FC-5	31 ½	800	4 ⅞	105	1 ⅞	48	1 ⅞	48
SM100-436FB-5	36	910	4 ½	114	BLIND	13	3 ½	89
SM100-09FB-5	9	230	6	152	BLIND	13	3 ½	89
SM100-09FF-5	9	230	6	152	BLIND	13	4 ½	114
SM100-11FD-5	11 ¼	290	6	152	3 ½	89	3 ½	89
SM100-12FB-5	12 ⅞	310	6	152	BLIND	13	3 ½	89
SM100-14FD-5	14 ½	370	6	152	3 ½	89	3 ½	89
SM100-16FD-5	16 ¼	410	6	152	3 ½	89	3 ½	89
SM100-18FB-5	18	460	6	152	BLIND	13	3 ½	89
SM100-22FD-5	22 ¼	560	6	152	3 ½	89	3 ½	89
SM100-24FB-5	24	610	6	152	BLIND	13	3 ½	89
SM100-24FE-5	24	610	6	152	BLIND	13	4 ⅞	105
SM100-24FF-5	24	610	6	152	BLIND	13	4 ½	114
SM100-29FD-5	28 ¾	730	6	152	3 ½	89	3 ½	89
SM100-30FB-5	30	760	6	152	BLIND	13	3 ½	89
SM100-30FD-5	30	760	6	152	3 ½	89	3 ½	89
SM100-30FE-5	30	760	6	152	BLIND	13	4 1/8	105
SM100-30FF-5	30	760	6	152	BLIND	13	4 ½	114
SM100-33FB-5	33 ¼	840	6	152	BLIND	13	3 ½	89
SM100-33FD-5	33 ¼	840	6	152	3 ½	89	3 ½	89
SM100-36FB-5	36	910	6	152	BLIND	13	3 ½	89
SM100-36FD-5	36	910	6	152	3 ½	89	3 ½	89
SM100-36FE-5	36	910	6	152	BLIND	13	4 ⅞	105
SM100-36FF-5	36	910	6	152	BLIND	13	4 ½	114
SM100-38FD-5	38	965	6	152	3 ½	89	3 ½	89
SM100-40FD-5	40	1020	6	152	3 ½	89	3 ½	89
SM100-40FE-5	40	1020	6	152	BLIND	13	4 ⅞	105
SM100-40FF-5	40	1020	6	152	BLIND	13	4 ½	114
SM100-43FB-5	43	1090	6	152	BLIND	13	3 ½	89
SM100-43FD-5	43	1090	6	152	3 ½	89	3 ½	89
SM100-44FB-5	44	1120	6	152	BLIND	13	3 ½	89
SM100-44FD-5	44	1120	6	152	3 ½	89	3 ½	89
SM100-44FE-5	44	1120	6	152	BLIND	13	4 ⅞	105
SM100-44FF-5	44	1120	6	152	BLIND	13	4 ½	114
SM100-48FD-5	48	1220	6	152	3 ½	89	3 ½	89
SM100-48FF-5	48	1220	6	152	BLIND	13	4 ½	114
SM100-56FB-5	56	1420	6	152	BLIND	13	3 ½	89
SM100-56FF-5	56	1420	6	152	BLIND	13	4 ½	114



Clay treaters are usually placed upstream of a coalescer separator system to remove surface active agents (surfactants), color and additives from jet fuel. These unwanted contaminants may be present in fuel at the processing and refining levels or picked up from various transportation methods such as trucks, ships and pipelines that carry several types of petroleum products in addition to jet fuel. The contaminant compounds will accumulate and disarm the coalescer cartridge and reduce the water coalescing efficiency of the coalescer separator. Clay treatment removes the surfactant compounds, color and additives by adsorption and delivers treated fuel to the coalescer separator while prolonging the life of the coalescer cartridges.

Clay treater housings have no internal moving parts. The product flows through the housing inlet chamber and equalizer tube. The equalizer tube evenly distributes product through each clay cartridge. Clay elements are vibra-packed to capacity with the highest grade of Attapulugus clay. This clay has the appearance of very fine sand, with each granule having hundreds of tiny, fiber-like crystals that capture molecular surfactants. The surface area of Attapulugus clay exceeds 13 acres per pound. Facet recommends a maximum flow of 7 gpm (26 lpm) per cartridge.

Facet clay treaters will continuously adsorb surfactants, color and additives from jet fuel when used with Facet replaceable clay elements. Housings are designed for easy servicing and low maintenance. Standard and optional accessories and connections are available to facilitate piping and installation requirements. Clay treaters provide a complete adsorptive system that delivers treated fuel while also prolonging cartridge life of the downstream filter separator.

### Standard Housing Design

- Welded carbon steel construction
- ASME Code, Section VIII construction, stamped and certified
- Design pressure: 150 psi @ 250 °F (10.3 bar @ 121 °C)
- Inlet and outlet permanently marked
- Interior: Epoxy coated (EI 1541)
- Exterior: Prime coated
- Removable cartridge mounting post
- Swing bolt closure
- Buna-N closure gasket
- Hydraulic headlift

### Standard Connections

- ¼" differential pressure gauge
- ¾" pressure relief valve and vent
- 2" main drain
- 1 ½" side drain

### Options

- Automatic air eliminator
- Automatic air eliminator check valve
- Differential pressure gauge
- Pressure relief valve
- Sampling probes
- Cartridge hoist assembly
- Removable bundle design

# F Series Clay Treater Housings

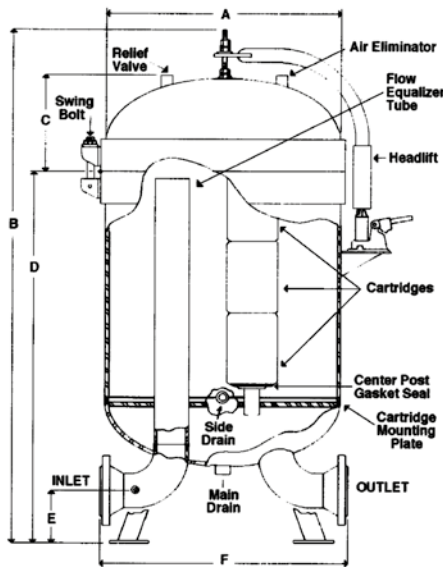

Typical Clay Treater Housing Flow Diagram  
(Including optional items)

## DATA

MODEL NUMBER	FLOW RATE		LIQUID VOLUME		REQUIRED CARTRIDGES	DRY WEIGHT		HOUSING TYPE
	gpm	lpm	gal	ltr		lbs	kg	
13F3-C	275	1041	288	1090	39	1913	868	Dished
24F3-C	500	1893	456	2067	72	3250	1474	Dished
31F3-C	650	2460	702	2657	93	4459	2023	Dished
40F3-C	840	3179	874	3308	120	5380	2440	Dished
50F3-C	1050	3974	1167	4417	150	6976	3164	Dished
60F3-C	1260	4769	1442	5458	180	8298	3764	Dished
67F3-C	1407	5325	1570	5942	201	9602	4355	Dished

Other sizes available on request.  
Weights and volumes are approximate.

## DIMENSIONS

MODEL NUMBER	INLET/OUTLET DIAMETER		DIMENSIONS												ANCHOR BOLT			
			A		B		C		D		E		F		BOLT CIRCLE		BOLT HOLE	
	in	mm	in	mm	in	mm	in	mm	in	mm	in	mm	in	mm	in	mm	in	mm
13F3-C	4	102	32	813	127 <sup>1</sup> / <sub>4</sub>	3232	12 <sup>3</sup> / <sub>4</sub>	324	87 <sup>1</sup> / <sub>2</sub>	2222	6	152	30	762	27 <sup>3</sup> / <sub>8</sub>	695	7 <sup>7</sup> / <sub>8</sub>	22
24F3-C	4	102	42 <sup>3</sup> / <sub>4</sub>	1086	134 <sup>3</sup> / <sub>16</sub>	3408	16 <sup>3</sup> / <sub>4</sub>	425	90 <sup>7</sup> / <sub>16</sub>	2297	6	152	30	762	36 <sup>1</sup> / <sub>2</sub>	927	7 <sup>7</sup> / <sub>8</sub>	22
31F3-C	6	152	48 <sup>3</sup> / <sub>4</sub>	1238	141	3581	18 <sup>3</sup> / <sub>4</sub>	476	95	2413	7 <sup>1</sup> / <sub>2</sub>	191	47	1194	40 <sup>1</sup> / <sub>2</sub>	1022	1 <sup>1</sup> / <sub>8</sub>	29
40F3-C	6	152	54 <sup>3</sup> / <sub>4</sub>	1391	145 <sup>5</sup> / <sub>16</sub>	3691	20 <sup>13</sup> / <sub>16</sub>	529	97 <sup>1</sup> / <sub>4</sub>	2470	7 <sup>1</sup> / <sub>2</sub>	191	43	1092	50	1270	1 <sup>1</sup> / <sub>8</sub>	29
50F3-C	8	203	60 <sup>3</sup> / <sub>4</sub>	1543	152 <sup>1</sup> / <sub>16</sub>	3878	23 <sup>1</sup> / <sub>4</sub>	591	102 <sup>3</sup> / <sub>4</sub>	2610	9	229	55	1397	52	1321	1 <sup>1</sup> / <sub>8</sub>	29
60F3-C	8	203	67	1702	154 <sup>3</sup> / <sub>4</sub>	3931	25 <sup>3</sup> / <sub>8</sub>	645	102 <sup>3</sup> / <sub>4</sub>	2610	9	229	60	1524	52	1321	1 <sup>1</sup> / <sub>8</sub>	29
67F3-C	8	203	73	1854	158	4013	27 <sup>5</sup> / <sub>8</sub>	702	104	2642	9	229	62	1574	56	1422	1 <sup>1</sup> / <sub>8</sub>	29

Other sizes available on request.

### NOTES:

- Housing model number will include clay treater cartridge model number when selected.
- Clay treater housings use Facet bag or canister style cartridges, 3 deep per stack.
- Clay treater cartridges are not installed at factory prior to shipment.



Facet's standard carbon steel FS Series SuperFlex<sup>™</sup> housings are small economical housings that can be used as clay treaters, but at lower flow rates than our standard F Series housings.

### Standard Housing Design

- Welded carbon steel construction—other materials available on request
- ASME Code, Section VIII construction, stamped and certified
- Design pressure: 250 psi @ 250 °F (17.2 bar @ 121 °C)
- Main closure: Blind Flange
- Head gasket: Buna-N—other materials available on request
- Vent connection: 3/4" NPT
- Drain connection: 3/4" 3000# NPT
- Inlet and outlet connections: 2" 3000# NPT
- Differential pressure gauge connection: 1/8" NPT
- Interior: Epoxy coated (EI 1541)
- Exterior: Prime coated

### Options

- Automatic air eliminator
- Automatic air eliminator check valve
- Manual drain valve
- Pressure gauge assembly
- Pressure relief valve
- Sampling probes
- Adjustable support stand

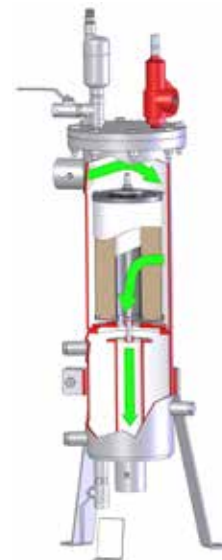

# FS Series SuperFlex™ Clay Treater Housings

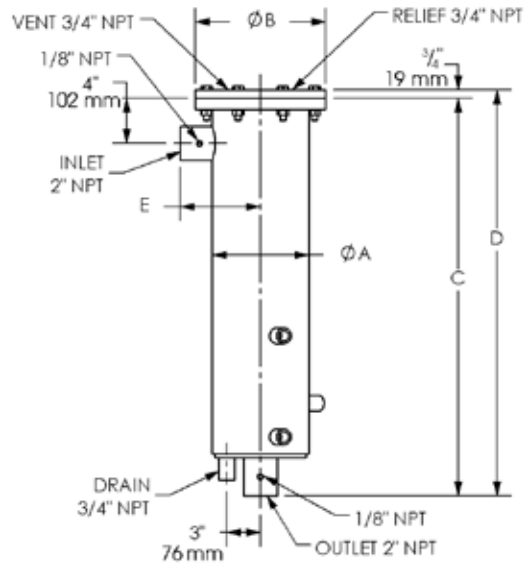

## DATA

MODEL NUMBER	JET FUEL		DIMENSIONS										WEIGHT		LIQUID VOLUME	
			A		B		C		D		E					
			in	mm	in	mm	in	mm	in	mm	in	mm				
FS-2C-A	7	26	8 <sup>5</sup> / <sub>8</sub>	219	11 <sup>1</sup> / <sub>2</sub>	295	49 <sup>7</sup> / <sub>8</sub>	1267	50 <sup>5</sup> / <sub>8</sub>	1285	7 <sup>1</sup> / <sub>8</sub>	181	125	56	10	38
FS-3C-A	14	52	8 <sup>5</sup> / <sub>8</sub>	219	11 <sup>1</sup> / <sub>2</sub>	295	63 <sup>7</sup> / <sub>8</sub>	1620	64 <sup>5</sup> / <sub>8</sub>	1641	7 <sup>1</sup> / <sub>8</sub>	181	200	90	13	49

FS-2C-A will hold (1) C-766-4 Clay Canister  
 FS-3C-A will hold (2) C-766-4 Clay Canisters



The primary purpose of clay treatment is to protect aviation fuel filtration systems and jet fuel by removing trace quantities of surfactants (surface active agents), color and additives commonly found in fuel.

Facet's specially selected Attapulugus clay greatly resists water saturation and provides maximum surfactant adsorptivity and filtration area found in clay treater cartridges.

### Standard Design Features

- Maximum adsorptive and filtration area
- Greatly resists water saturation
- Vibra-packed clay minimizes settling
- Interchangeable with other manufacturer's bag and canister clay treater cartridges
- Hoisting handles expedite cartridge installation and changeout
- Flow direction: Outside to in

### Materials

#### Bag Cartridge

- Polypropylene center tube
- Felt center tube migration barrier
- Tightly woven canvas bag
- Vibra-packed with Attapulugus clay to capacity
- Heavy-duty canvas hoisting handles

#### Canister Cartridge

- Perforated metal center tube
- Non-woven polyester inner migration barrier
- Vibra-packed with Attapulugus clay to capacity
- Heavy-duty metal hoisting handle
- Reinforced Plastic Endcaps
- Polyester outer wrap
- Buna-N gaskets on both ends for assured sealing

### DATA

MODEL NUMBER	TYPE	RECOMMENDED FLOW RATE PER CARTRIDGE		MEDIA	DIMENSIONS						MAXIMUM OPERATING TEMPERATURE	
					NOMINAL LENGTH		OUTSIDE DIAMETER		INSIDE DIAMETER			
					gpm	lpm	in	mm	in	mm	in	mm
C-766-4	Canister	5-7	19-27	Attapulugus clay, low volatile material Graded 60-90 mesh	18	457	7	178	2¼	57	240	115
C-727-6	Bag	5-7	19-27		18	457	7	178	2¼	57	140	60
C-727-2	Bag	5-7	19-27		19	482	7	178	2¼	57	140	60



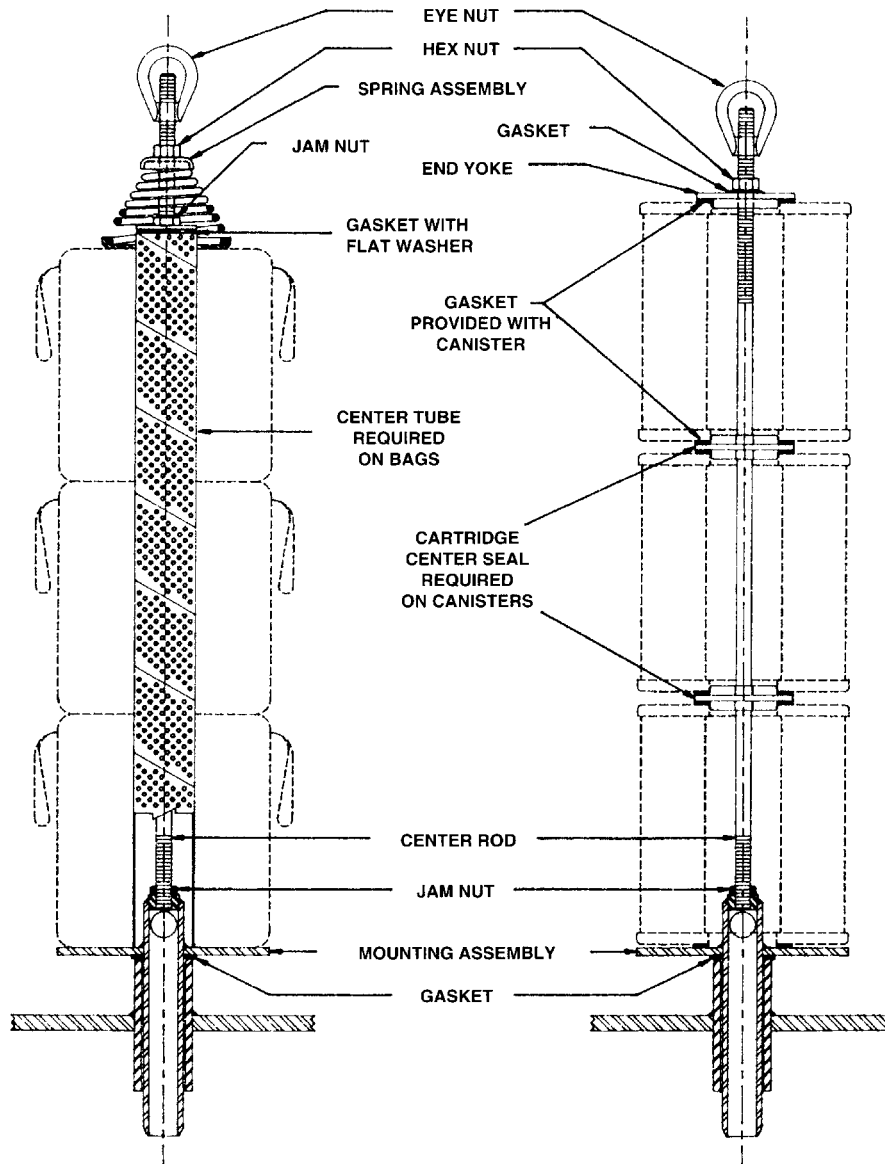

Bag style mounting

Canister style mounting





Facet filter housings are specifically designed to remove solid particles such as rust, dirt, pipe scale, sand and metal from fuel. They are commonly located ahead of clay treaters and coalescer separators to protect and prolong cartridge life. A single pass through the filter allows clean product to flow downstream.

Facet filter housings will continuously remove solids from fuel when used with Facet standard single, double or triple-length FA, M OR CIF Series high efficiency filter cartridges. Housings are designed for easy servicing and low maintenance. All are built to ASME Code, Section VIII, with many standard and optional accessories and connections available to facilitate individual installation requirements. Facet filters provide a complete system to meet industry standards and levels of effluent purity required by commercial airlines, major oil companies and governments, worldwide.

M Series filter housings use any of Facet's high efficiency filter cartridges. A single pass of product through the system removes solids such as rust, dirt, scale, granules and other particles commonly found in liquid process streams.

M Series filter housings are available in three styles and in several standard sizes to accommodate specific flow and filtration requirements. They are designed with no internal moving parts to provide easy service

and reduced maintenance costs. Each housing is manufactured using quality materials and workmanship to give long-lasting, dependable service.

M Series filter housings can be fitted with either multiple single-length cartridges, stacked 1, 2 or 3 high or their double-length or triple-length equivalents.

### Standard Housing Design

- EI 1596 Design & Construction or applicable design code
- Body: Welded carbon steel construction other materials available on request
- ASME Code, Section VIII construction, stamped and certified
- Designed for 150 psi @ 250°F (10.3 bar @ 121 °C) — higher pressure and temperature ratings available on request
- Head closures: Style A — thru-bolt; Styles B and C — swing bolt
- Buna-N closure gasket — other materials available on request
- Rod mount cartridge hardware
- Knife edge cartridge mounting seals
- Headlift furnished on 20" (508 mm) and larger
- Inlet and outlet permanently marked
- Exterior: Prime coated
- Interior: Epoxy coated (EI 1541)

### Standard Connections

- Inlet and outlet: Style A — 3000# NPT; Style B and C — 150# RF (ANSI) flanged
- Side and bottom drain: 3000# NPT
- Vent and relief valve: 3/4" 3000# NPT
- Pressure gauge: 1/4" 3000# NPT

### Options

- Automatic air eliminator\*
- Automatic air eliminator check valve
- Differential pressure gauge\*
- Pressure relief valve\*
- Manual drain valve
- Sample probes\*

\*Mandatory for EI 1596

# M Series Filter Housings

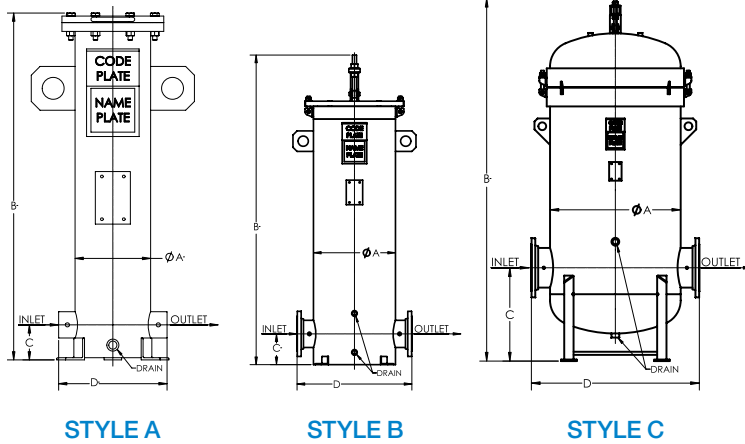

## DATA

MODEL NUMBER	MAXIMUM FLOW RATE <sup>(9)</sup>		CONNECTIONS						ANCHOR BOLT PLAN				WEIGHT WITH CARTRIDGES		
			INLET/OUTLET		SIDE DRAIN		BOTTOM DRAIN		BOLT HOLE DIAMETER		BOLT CIRCLE				NO. OF BOLT HOLES
			in	mm	in	mm	in	mm	mm	in	mm	in			
1M-114	66	250	2	51	N/A	N/A	3/4	19	7/8	22	11 1/8	295	3	110	50
1M-214	133	503	2	51	N/A	N/A	3/4	19	7/8	22	11 1/8	295	3	140	64
1M-314	200	757	2	51	N/A	N/A	3/4	19	7/8	22	11 1/8	295	3	160	73
2M-314	400	1514	4	102	3/4	19	3/4	19	7/8	22	17	432	4	450	204
3M-314	600	2271	4	102	3/4	19	3/4	19	7/8	22	19	483	4	525	238
4M-314	800	3028	6	152	3/4	19	3/4	19	7/8	22	21	533	4	650	295
6M-314	1200	4542	6	152	3/4	19	3/4	19	7/8	22	23	584	4	775	352
11M-314	2200	8328	8	203	1 1/2	38	1	25	7/8	22	24 5/8	625	4	1225	556
18M-314	3600	13627	10	254	1 1/2	38	1	25	7/8	22	31 1/8	797	4	1950	885
27M-314	5400	20441	12	305	1 1/2	38	1 1/2	38	1	25	39 3/8	1000	4	2700	1225

Other sizes available on request.

## DIMENSIONS

MODEL NUMBER	DIMENSIONS								HOUSING LIQUID VOLUME		HOUSING TYPE
	A		B		C		D				
	in	mm	in	mm	in	mm	in	mm	gal	ltr	
1M-114	8 5/8	219	24 1/4	616	4	102	12 3/8	314	5	19	Style A - Flat
1M-214*	8 5/8	219	39 1/2	1003	4	102	12 3/8	314	9	34	Style A - Flat
1M-314*	8 5/8	219	54 1/2	1378	4	102	12 3/8	314	12	45	Style A - Flat
2M-314*	14	355	72 3/4	1848	6	152	22	559	36	136	Style B - Flat
3M-314*	16	406	72 3/4	1848	6	152	24	610	48	182	Style B - Flat
4M-314*	18	457	75 1/4	1911	7 1/2	191	26	660	63	238	Style B - Flat
6M-314*	20	508	75 1/2	1918	7 1/2	191	28	711	78	295	Style B - Flat
11M-314	28	711	103 3/4	2623	24	610	36	914	205	776	Style C - Dished
18M-314	34	864	109 1/2	2781	27	686	46	1168	315	1192	Style C - Dished
27M-314	42	1067	116 3/4	2965	30	762	54	1371	520	1968	Style C - Dished

### NOTES:

- Cartridges are selected separately to fit specific application requirements.
- Multiple stack cartridges should be replaced with one single-length equivalent. Example: 1M-214 = 1M-128 or 6M-314 = 6M-143, etc.
- Consult factory for flow rates when using EI 1590 Qualified Elements.

All dimensions, weights and volumes are approximate and are for estimating purposes only.

\* These models do not comply with EI v specs. Please contact your nearest Facet location for further information.



Facet's standard carbon steel MS Series SuperFlex<sup>™</sup> filter housings are small, economical housings for in-line removal of solids from aviation fuels when equipped with Facet's FA, M or CIF Series High Efficiency filter cartridges.

### Standard Housing Design

- Welded carbon steel construction
- ASME Code, Section VIII construction, stamped and certified
- Design pressure: 250 psi @ 250 °F (17.2 bar @ 121 °C)
- Main closure: Blind flange
- Head gasket: Buna-N—other materials available on request
- Vent connection: 3/4" NPT
- Drain connection: 3/4" 3000# NPT
- Inlet and outlet connections: 2" 3000# NPT
- Differential pressure gauge connection: 1/8" NPT
- Interior: Epoxy coated (EI 1541)
- Exterior: Prime coated

### Options

- Air eliminator
- Air eliminator check valve
- Manual drain valve
- Pressure gauge assembly
- Pressure relief valve
- Sampling probe
- Adjustable support stand

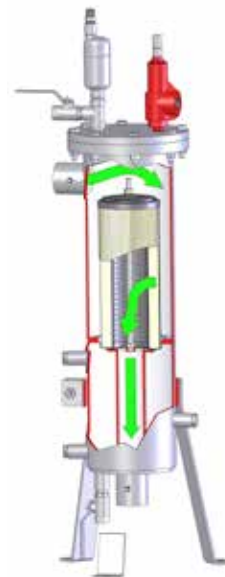

# MS Series SuperFlex™ Filter Housings

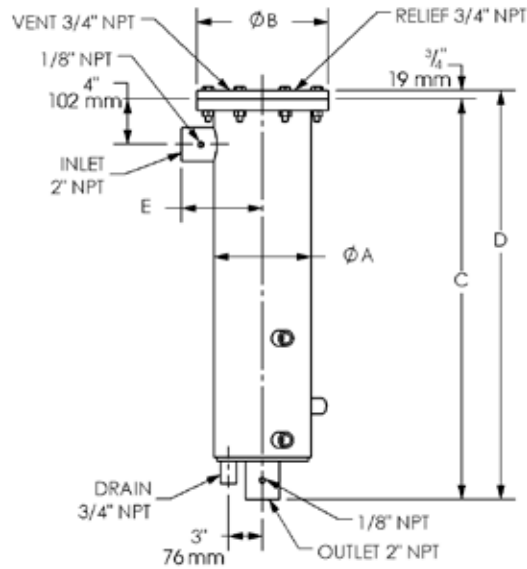

## DATA

MODEL NUMBER	MAXIMUM FLOW RATE*		DIMENSIONS										WEIGHT		LIQUID VOLUME	
			A		B		C		D		E					
			in	mm	in	mm	in	mm	in	mm	in	mm				
MS-1C-A	66	250	8 $\frac{5}{8}$	219	11 $\frac{5}{8}$	295	35 $\frac{5}{8}$	899	36 $\frac{5}{8}$	918	7 $\frac{1}{8}$	181	100	45	7	26
MS-2C-A	133	503	8 $\frac{5}{8}$	219	11 $\frac{5}{8}$	295	49 $\frac{5}{8}$	1267	50 $\frac{5}{8}$	1286	7 $\frac{1}{8}$	181	125	56	10	38
MS-3C-A	200	757	8 $\frac{5}{8}$	219	11 $\frac{5}{8}$	295	63 $\frac{5}{8}$	1622	64 $\frac{5}{8}$	1641	7 $\frac{1}{8}$	181	200	90	13	49

Initial Pressure Drop 2 psig

Cartridges are selected separately to fit specific application requirements and will be included in the final housing model number.

All dimensions, weights and volumes are for estimating only.

\*Consult factory for flow rates when using EI1590 Qualified Elements (FA Series).

## Fuel-Gard® VF-21SB/22SB Microfilter



The Facet VF-21SB/22SB can be used as a filter housing. They are versatile, compact, light weight housings and provide superior in-line filtration protection. Both interior and exterior surfaces of the carbon steel body are epoxy coated to protect against corrosion. This sturdy, single cartridge housing is easy to maintain and requires only 2" (51 mm) base clearance for cartridge change out.

### Standard Housing Design

- Body: Carbon steel
- Aluminum Head
- Interior and exterior: Epoxy coated
- Design pressure: 150 psi (10.3 bar)
- Closure: Swing-bolt
- Closure seal: Buna-N o-ring—other materials available upon request
- Vent and drain connections with brass petcocks provided
- Inlet and outlet connections: 1½" NPT female threaded
- One filter cartridge installed

### VESSEL OPTIONS

MODEL	DESCRIPTION
VF-21SB	Housing only
VF-21SB-PG	Housing w/ Direct Reading Differential Pressure Gauge
VF-21SB-PG2	Housing with 1/8" NPT connection to accommodate an external differential pressure gauge (supplied by others)
VF-22SB	Housing only
VF-22SB-PG	Housing w/ Direct Reading Differential Pressure Gauge
VF-22SB-PG2	Housing with 1/8" NPT connection to accommodate an external differential pressure gauge (supplied by others)
644160	Mounting Bracket
644964	Grounding Cable
606521	Closure O-Ring

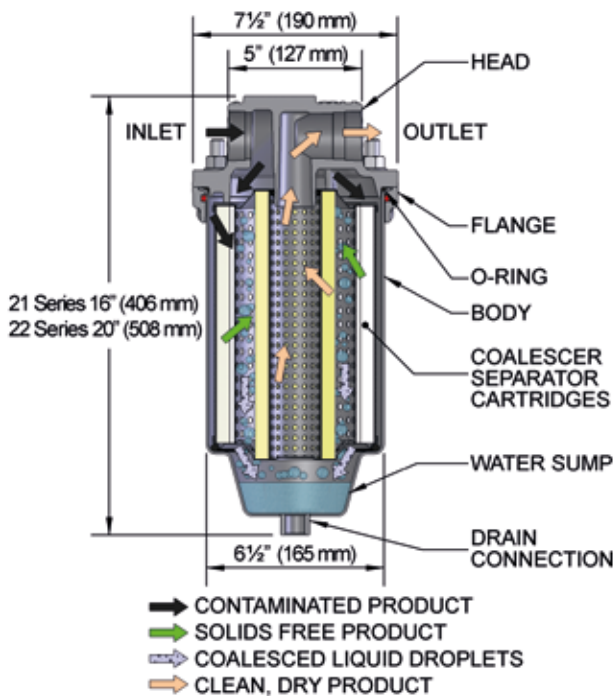

Differential Pressure Indicator - The piston-type differential pressure indicator provides a simple visual warning. When 15 psi (1.03 bar) differential pressure is reached, the gauge indicator moves from green to red zone. This warning will prevent premature cartridge change-out.

ACCORDING TO THE REQUIREMENTS OF EUROPEAN PRESSURE EQUIPMENT DIRECTIVE (PED) 2014/68/EU ART. 4.3, WITHIN THE OPERATING LIMITS PROVIDED ON VESSEL NAMEPLATE AND SUMMARIZED BELOW, THESE FILTERS ARE DESIGNED AND MANUFACTURED IN ACCORDANCE WITH THE SOUND ENGINEERING PRACTICE AND EXEMPT FROM CE MARKING AND CERTIFICATION: 10 BAR(G) @ 35°C FOR AV-GAS AND JET FUEL.

# Fuel-Gard® VF-21SB/22SB Filter

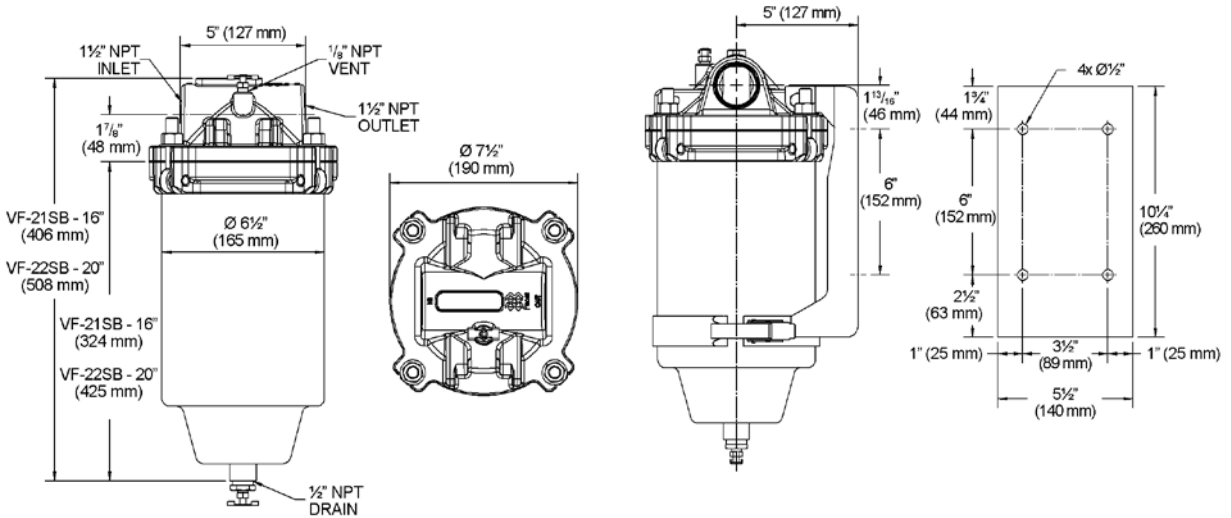

**Optional Mounting Bracket**



The purpose of this bonding kit is to lessen the potential for static charge build up in the metal body of these vessels. This kit will allow the bowl, previously isolated because of the epoxy powder coating, to be bonded to system piping. One end of the bonding wire consists of a clamp that tightens onto the 1-1/2" piping. The other end has a heavy duty spring clamp that can be attached to the drain line valve. Remember if placing either end on a painted surface to scratch down to bare metal to allow contact.

This kit, part # 644964 can be purchased separately for existing vessels.







Facet VF-21SB/22SB Series filter cartridges provide long service life and high solids holding capacity with no unloading characteristics. The filter cartridges remove solids.

### Standard Design Features

- 2 and 5 Micron Cartridges—other Micron ratings available upon request
- Recommended maximum operating temperature: 240 °F (115 °C)
- Maximum differential pressure: 75 psi (5.17 bar)
- pH range from 5 to 9
- Flow direction: Outside to in

### Materials

- Carbon steel structural components
- All metal components coated to protect against corrosion
- Standard gaskets are Buna-N—other materials available on request

### DATA

MODEL NUMBER	NOMINAL LENGTH		OUTSIDE DIAMETER		SHIPPING WEIGHT		JET FUEL				AV-GAS				
							INITIAL ΔP		FLOW		INITIAL ΔP		FLOW		
	in	mm	in	mm	lbs	kg	psi	kPa	gpm	lpm	psi	kPa	gpm	lpm	
<b>21 Series</b>															
CF-609-2PLO	9	230	6	152	4	1.8	2.1	14.5	45	170	1.2	8.3	45	170	
CF-609-5PLO	9	230	6	152	4	1.8	2.1	14.5	45	170	1.2	8.3	45	170	
<b>22 Series</b>															
CF-612-2PLO	12	300	6	152	6	2.7	3.1	21.4	60	227	1.6	11.0	60	227	
CF-612-5PLO	12	300	6	152	6	2.7	3.1	21.4	60	227	1.6	11.0	60	227	

\* For applications other than AV-Gas and Jet Fuel, please contact the nearest Facet office.

\*\*DP given for viscosity <2 cSt



### FA-CIF Series Microfilters

Qualified to EI 1590

### High-Performance, Sustainable Filtration

FA-CIF Series elements deliver exceptional solids removal performance while reducing environmental impact.

#### Key Features

- Qualified to EI 1590 for aviation fueling applications
- Up to 45% lighter than standard microfilters, lowering freight costs and transportation emissions
- Streamlined installation reduces changeout time by up to 4 hours while improving operator safety
- Crushable to 20% of original size, cutting disposal costs and waste volume by up to 80%
- Metal-free construction enables complete incineration of used filter elements

#### Specifications

- **Outside Diameter:** 6" (152 mm)
- **Inside Diameter:** 3.5" (89 mm)
- **Max Operating Temperature:** 240 °F (115 °C)
- **Initial Differential Pressure:** 2 psid (0.14 bar) or less
- **Terminal Differential Pressure:** 15 psid (1.03 bar)
- **Design Collapse Pressure:** 75 psid (5.17 bar)
- **pH Range:** from 5 to 9
- **Flow Direction:** Outside to In



Model Number	Micron Rating	Nominal Max Flow Rate per Element	Nominal Length	Center Tube Kit Part Number*
FA-614-1ACIF	1	53 gpm (201 lpm)	14½" (370 mm)	CIF1KIT
FA-614-2ACIF	2	53 gpm (201 lpm)	14½" (370 mm)	CIF1KIT
FA-614-3ACIF	3	53 gpm (201 lpm)	14½" (370 mm)	CIF1KIT
FA-614-5CIF	5	72 gpm (273 lpm)	14½" (370 mm)	CIF1KIT
FA-628-1ACIF	1	111 gpm (420 lpm)	28¾" (730 mm)	CIF2KIT
FA-628-2ACIF	2	111 gpm (420 lpm)	28¾" (730 mm)	CIF2KIT
FA-628-3ACIF	3	111 gpm (420 lpm)	28¾" (730 mm)	CIF2KIT
FA-628-5CIF	5	138 gpm (522 lpm)	28¾" (730 mm)	CIF2KIT
FA-644-1ACIF	1	169 gpm (640 lpm)	44" (1118 mm)	CIF3KIT
FA-644-2ACIF	2	169 gpm (640 lpm)	44" (1118 mm)	CIF3KIT
FA-644-3ACIF	3	169 gpm (640 lpm)	44" (1118 mm)	CIF3KIT
FA-644-5CIF	5	210 gpm (795 lpm)	44" (1118 mm)	CIF3KIT
FA-656-1ACIF	1	227 gpm (859 lpm)	56" (1422 mm)	CIF4KIT
FA-656-2ACIF	2	227 gpm (859 lpm)	56" (1422 mm)	CIF4KIT
FA-656-3ACIF	3	227 gpm (859 lpm)	56" (1422 mm)	CIF4KIT

\* Using CIF Series cartridges requires the one-time installation of a Center Tube Kit. Each kit provides everything needed for a simple, one-time conversion of your existing 6" cartridge housings to accommodate coreless, metal-free CIF Cartridges.





Facet FA Series microfilters offer superior filtration for removing ultra-fine solid contaminants such as rust, scale, granular and other types of solids from aviation fuel systems. They are designed to flow from the outside to inside.

Facet FA Series microfilters are manufactured using proprietary combinations of Micro Fiberglass and Cellulose to achieve the desired removal rating.

### Benefits

- FA Series media provides high efficiencies, superior strength and durability
- One piece construction reduces downtime, cartridge change-out costs and eliminates filter bypass concerns
- Retention ratings available in 1, 2, 3 and 5 microns
- All metal components are treated against corrosion. Spirally wound core reduces weight resulting in lower freight costs

### Standard Design Features

- Removal Efficiency: Effluent solids <0.15 mg/liter
- Structural Strength: 75 psi (5.17 bar)

### Materials

- Filter Media: Micro Fiberglass/Cellulose
- End Caps: Steel Powder Coated
- Center Tube: Spiral Wound Steel Powder Coated
- Gaskets: Buna-N
- Adhesive: Plastisol

### FILTER SIZE AND DIMENSIONS

MODEL NUMBER	MICRON	FLOW RATE		NOMINAL LENGTH		OUTSIDE DIAMETER		INSIDE DIAMETER	
		gpm	lpm	in	mm	in	mm	in	mm
FA-614-1A	1	55	208	14½	370	6	152	3½	89
FA-628-1A	1	113	428	28¾	730	6	152	3½	89
FA-644-1A	1	176	666	44	1118	6	152	3½	89
FA-614-2A	2	55	208	14½	370	6	152	3½	89
FA-628-2A	2	113	428	28¾	730	6	152	3½	89
FA-644-2A	2	176	666	44	1118	6	152	3½	89
FA-614-3A	3	55	208	14½	370	6	152	3½	89
FA-628-3A	3	113	428	28¾	730	6	152	3½	89
FA-644-3A	3	176	666	44	1118	6	152	3½	89
FA-614-5	5	62	235	14½	370	6	152	3½	89
FA-628-5	5	128	485	28¾	730	6	152	3½	89
FA-644-5	5	200	757	44	1118	6	152	3½	89
FA-614-5CIF	5	62	235	14½	370	6½	155	3⅞	97
FA-628-5CIF	5	128	485	29⅞	740	6½	155	3⅞	97
FA-644-5CIF	5	200	757	43¾	1111	6½	155	3⅞	97





The Facet M Series high efficiency pleated paper filter cartridges are excellent for removing solid contaminants such as rust, dirt, scale, granular and other types of solids from fuels. Media with high efficiencies throughout the life of the cartridges are available to the aviation market in ratings of 0.5 to 15 nominal microns. These cartridges can be provided with either a perforated paper or expandable metal outer wrap if required.

Facet M Series high efficiency pleated paper filter cartridges are pleated paper filter media made from a variety of natural and synthetic fibers. The fibers are bonded using various resins to provide excellent filtration and solids holding characteristics.

These cartridges are all 6" (152 mm) outside diameter and 3½" (89 mm) inside diameter. To simplify maintenance, we offer one piece cartridges in three lengths—single-length of 14½" (370 mm), double-length of 28¾" (730 mm), and triple-length of 43¼" (1090 mm). One triple length cartridge replaces three single-length.

### Benefits

- Higher efficiency and longer service life equals lower operating costs
- High efficiency cartridge provides superior solids holding capacity
- Spiral wound core reduces cartridge weight resulting in lower freight costs

### Standard Design Features

- Recommended maximum operating temperature: 240 °F (115 °C)
- Maximum differential pressure: 75 psi (5.17 bar)
- Flow direction: Outside to in
- pH range from 5 to 9
- Single-piece construction
- "Rod Mount" or "Screw base" options available

### Materials

- All metal components coated to protect against corrosion
- Gaskets are Buna-N—other materials available on request
- Perforated paper or expanded metal outer wrap is available if required

### DATA

MODEL NUMBER	MICRON	NOMINAL LENGTH	
		in	mm
MP0.5	0.5	14½	370
MP0.5L	0.5	14½	370
MP0.5LX2	0.5	28¾	730
MP0.5X2	0.5	28¾	730
MP0.5LX3	0.5	44	1118
MP0.5LX3SB	0.5	44	1118
MP1	1	14½	370
MP1L	1	14½	370
MP1LX2	1	28¾	730
MP1X2	1	28¾	730
MP1LX3	1	44	1118
MP1LX3SB	1	44	1118
MP2	2	14½	370
MP2L	2	14½	370
MP2LX2	2	28¾	730
MP2LX3	2	44	1118
MP5	5	14½	370
MP5L	5	14½	370
MP5LX2	5	28¾	730
MP5X2	5	28¾	730
MP5LX3	5	44	1118
MP5LX3SB	5	44	1118





The Facet CIF Series high efficiency pleated paper filter cartridges are designed to effectively remove solid contaminants from fuels.

Media with high efficiency throughout the life of the cartridge is available in ratings from .5 to 5 microns. We recommend replacing cartridges when the differential pressure reaches 15 psi (1.03 bar). Effective life above 15 psi (1.03 bar) is minimal.

All cartridges are 6" (152 mm) outside diameter. To simplify maintenance, we offer one piece cartridges in three lengths: single-length of 14½" (370 mm), double-length of 28¾" (730 mm) and triple-length of 43¼" (1090 mm). One triple-length cartridge replaces three single-length.

To use the CIF Series cartridge requires the one time installation of either a single, double or triple-length center tube kit. Each kit contains all necessary hardware and components required to convert any housing fitted for 6" (152 mm) OD x 3½" (89 mm) ID diameter cartridges.

### Benefits

- Crushable—can reduce your disposal volume by approximately 80%
- No metal components
- Incinerable—check your local regulations
- Pleat spacers—designed for maximum utilization of the filter medium
- Flow rates are comparable to other 6" (152 mm) OD cartridges
- Cartridge alignment is executed at top of center tube—easier, quicker
- Lightweight—contributes to reducing changeout time

### Standard Design Features

- Recommended maximum operating temperature: 240 °F (115 °C)
- pH range from 5 to 9
- Initial differential pressure: 2 psi (0.14 bar) or less
- Design collapse pressure: 75 psid (5.17 bar)
- Flow direction: Outside to in

### Materials

- Constructed with high efficiency pleated paper
- No metal components—end caps and center tubes are engineered plastics
- Gaskets are Buna-N—other materials available by request

### DATA

MODEL NUMBER	MICRON	NOMINAL LENGTH	
		in	mm
CIF0.5LX3	0.5	44½"	1133
CIF1	1	14½"	370
CIF1X2	1	28¾"	730
CIF1LX3	1	44½"	1133
CIF2	2	14½"	370
CIF2X2	2	28¾"	730
CIF2LX3	2	44½"	1133
CIF5	5	14½"	370
CIF5X2	5	28¾"	730
CIF5LX3	5	44½"	1133



### PARTS FOR ASSEMBLY

ITEM	PART NUMBER	DESCRIPTION	QUANTITY		
			CIF1KIT for 14½" Cartridge	CIF2KIT for 28¾" Cartridge	CIF3KIT for 43¾" Cartridge
1	606443	Hex Nut ½" -13C-2B	1	1	1
2	640442	Center Tube Assembly	1	2	3
3	640444	Top Adaptor	1	1	1
4	640445	Centering Guide	0	1	2
5	640443	Bottom Guide	1	1	1
6	606450	Jam Nut ½" -13C-2B	1	1	1
7	640549	Yoke	1	1	1
8		Filter Cartridge	*	*	*
9		Gasket Washer	*	*	*
10	6056402	Flat Washer	1	1	1
11	606705	Lock Washer	1	1	1

\* NOT INCLUDED. SHOWN FOR REFERENCE ONLY.

### Installation Instructions:

#### To Install The CIF Series Center Tube

1. Remove existing filter cartridge.  
NOTE: Leave center rod in position.
2. Identify bottom of center tube. Only the top of center tube will accept top adaptor (3).
3. Place center tube assembly with the bottom guide (5) down making sure it is properly aligned on the existing cartridge adaptor.
4. For kit numbers CIF2 and CIF3, be sure to properly align centering guide (4) over center rod.
5. Slide top adaptor (3) over center rod and secure in center tube using jam nut (6) (thinner of two nuts). Tighten to 5 foot pounds (6.78 Nm).

At this point you have successfully installed your permanent center tube.

#### To Install the CIF Series Cartridge

1. Slide cartridge over center tube. Install NEW black yoke (7) domed head up.
2. Place rubber gasket washer (9) (supplied with filter cartridge) over center rod.
3. Place flat steel washer (10) over rubber gasket washer.
4. Place steel lock washer (11) over flat steel washer and secure 5 foot pounds (6.78 Nm) with hex nut (1).

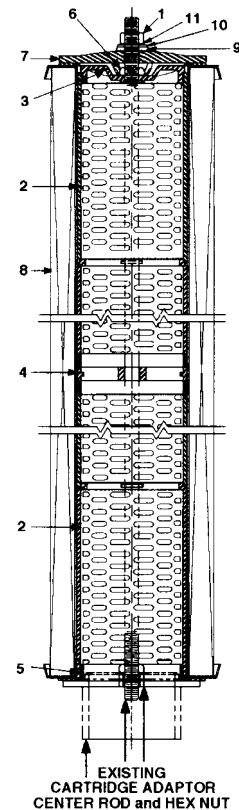





The Facet Flushing Filter elements are designed to be used in place of coalescer elements in a coalescer separator vessel during flushing on new systems or when there's been repairs to the existing equipment. The elements are less expensive than coalescer elements and have more filtration media for better solids holding capacity. Benefits, features and materials of construction are similar to our MP Series filter elements, except designed to flow inside to outside same as coalescer cartridges.

#### Benefits

- Less expensive than coalescer cartridges
- More solids holding capacity than coalescer cartridges
- Less weight resulting in lower freight costs

#### Standard Design Features

- Recommended maximum operating temperature: 240 °F (115 °C)
- Maximum differential pressure: 75 psi (5.17 bar)
- Flow direction: Inside to out
- pH range from 5 to 9
- Single-piece construction
- “Rod Mount” or “Screw base” options available

#### Materials

- All metal components coated to protect against corrosion
- Gaskets are Buna-N—other materials available on request
- Metal outer shell and core

#### DATA

MODEL NUMBER	MICRON RATING	NOMINAL LENGTH		OUTSIDE DIAMETER		INSIDE DIAMETER		MOUNTING STYLE
		in	mm	in	mm	in	mm	
MPI-622-2SB	2	23	580	6	152	3½	89	Screw Base
MPI-628-2SB	2	28¾	730	6	152	3½	89	Screw Base
MPI-633-5SB	5	34	860	6	152	3½	89	Screw Base
MPI-638-5SB	5	39	990	6	152	3½	89	Screw Base
MPI-643-0.5SB	0.5	45	1140	6	152	3½	89	Screw Base
MPI-643-5	5	43¼	1100	6	152	3½	89	Rod Mount
MPI-643-5SB	5	45	1140	6	152	3½	89	Screw Base
MPI-656-0.5SB	0.5	57	1450	6	152	3½	89	Screw Base
MPI-656-1	1	56¼	1430	6	152	3½	89	Rod Mount
MPI-656-2SB	2	57	1450	6	152	3½	89	Screw Base
MPI-656-5	5	56¼	1430	6	152	3½	89	Rod Mount
MPI-656-5SB	5	57	1450	6	152	3½	89	Screw Base

NOTE: Other lengths & micron rating available





Facet HP Series single-stage water coalescers, commonly referred to as repack or hay pack housings, are horizontal, cylindrically shaped housings designed to protect filtration systems from gross amounts of water and solid contaminants. Facet recommends using their wafer style repack coalescers since they allow the first two sections to be replaced when required. The third and successive sections require fewer change outs since they may remain relatively free of solids.

Coalescing first starts as the product enters the vessel. Due to the substantially reduced velocity, free water will fall out by gravity. While the product progresses through the mass packed media, further coalescing occurs by impingement of water droplets on the media. At the same time, solids tend to fall out as the liquid enters the housing at a reduced velocity, but are further removed by filtration as the flow continues through the mass media.

All Facet HP Series single-stage water coalescer housings are built to ASME Code, Section VIII, with many standard and optional accessories available to facilitate individual installation requirements.

Facet HP Series single-stage coalescers use wafer repacks to remove gross amounts of water and solids from fuel. They are available in several standard sizes to accommodate flows from 10 to 2000 gpm (38 to 7570 lpm). They provide protection to filtration systems from gross amounts of water and solids that are commonly carried through inbound transport pipelines.

HP Series housings offer an option of using coalescer cartridges for more efficient solids separation and liquid-liquid water separation. Use of an adaptor kit permits returning to the use of repacks at any time.

HP Series housings have no internal moving parts and are designed for easy servicing, thereby reducing maintenance costs. Each housing is manufactured with quality workmanship and materials to give long-lasting and dependable service.

### Standard Housing Design

- Welded carbon steel construction
- ASME Code, Section VIII construction, stamped and certified
- Design pressure: 150 psi @ 250 °F (10.3 bar @ 121 °C)
- Housing closure
  - Blind cover on housings less than 14" (356 mm) OD
  - Swing bolt closure on housings 14" (356 mm) OD and larger
- Housing covers
  - Removable on housings up to 14" (356 mm) OD
  - Hinged on housings 14" (356 mm) thru 36" (914 mm) OD
  - Rotating davits on housings 42" (1067 mm) OD and larger

### Standard Connections

- Inlet and outlet: 150# RF (ANSI) flanged
- All other connections are 3000# NPT female type couplings

### Options

- Steel stands available
- Internal epoxy coating

# HP Series Single-Stage Coalescer Housings

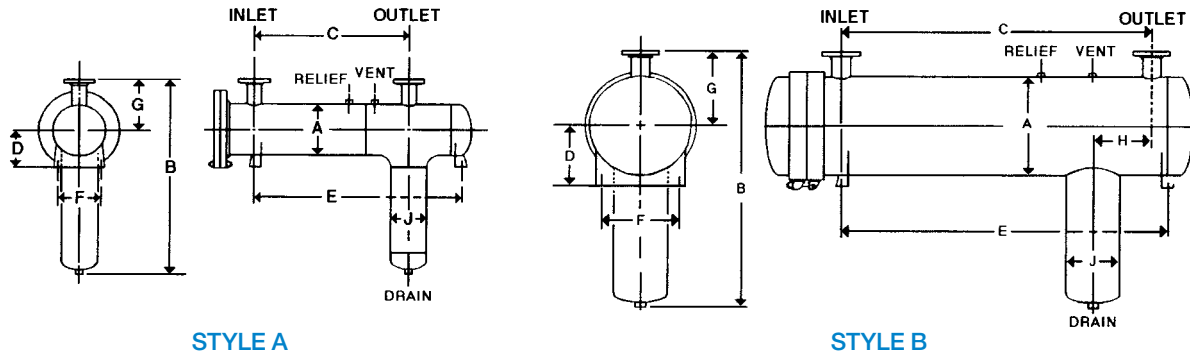

## DATA

MODEL NUMBER	FLOW RATES <sup>(1)</sup>		LIQUID VOLUME		SHIPPING WEIGHT		CONNECTIONS									
							INLET/OUTLET DIAMETER		VENT AND RELIEF		DRAIN		LEVEL GAUGE		LEVEL CONTROL	
	gpm	lpm	gal	ltr	lbs	kg	in	mm	in	mm	in	mm	in	mm	in	mm
<b>Style A</b>																
HP-10	6	23	2	7	150	68	1	25	1/2	13	1/2	13	3/4	19	3/4	19
HP-25	15	57	10	38	310	141	1 1/2	38	1/2	13	1/2	13	3/4	19	3/4	19
HP-50	26	98	18	68	345	156	1 1/2	38	1/2	13	1/2	13	3/4	19	3/4	19
HP-100	60	227	46	174	1550	703	3	76	3/4	19	3/4	19	3/4	19	1	25
<b>Style B</b>																
HP-150	100	379	77	291	1815	824	3	76	3/4	19	3/4	19	3/4	19	1 1/2	38
HP-200	155	587	152	575	2100	954	3	76	1	25	1	25	3/4	19	1 1/2	38
HP-300	225	852	201	761	2300	1045	4	102	1	25	1 1/2	38	3/4	19	1 1/2	38
HP-500	350	1325	313	1185	3100	1407	6	152	1	25	1 1/2	38	3/4	19	1 1/2	38
HP-750	510	1930	610	2309	4000	1816	6	152	1 1/2	38	2	51	3/4	19	1 1/2	38
HP-1000	720	2725	742	2809	4600	2088	8	203	1 1/2	38	2	51	3/4	19	2	51
HP-1500	940	3558	969	3668	5200	2361	8	203	1 1/2	38	2	51	3/4	19	2	51
HP-1800	1200	4542	1428	5405	6200	2815	10	254	1 1/2	38	2	51	3/4	19	2	51
HP-2000	1425	5394	2116	8010	8000	3632	10	254	1 1/2	38	2	51	3/4	19	2	51

(1) Flow rates based on Jet Fuel @ .79 specific gravity.

## DIMENSIONS

MODEL NUMBER	A		B		C		D		E		F		G		H		J	
	in	mm	in	mm	in	mm	in	mm	in	mm	in	mm	in	mm	in	mm	in	mm
<b>Style A</b>																		
HP-10	4 1/2	114	35 1/8	892	24	610	5	127	30 3/4	768	8	203	8	203	--	--	4 1/2	114
HP-25	6 5/8	168	37 1/2	953	33	838	6	152	41	1041	6	152	9	229	--	--	6 5/8	168
HP-50	8 5/8	219	44 1/2	1130	35 1/2	902	7	178	48 1/2	1232	8	203	10	254	--	--	8 5/8	219
HP-100	12 3/4	324	47	1193	48	1219	9	229	60 1/2	1537	10	254	12	305	--	--	8 5/8	219
<b>Style B</b>																		
HP-150	16	406	51	1295	60	1524	11	279	66	1676	11	279	14	356	4	102	8 5/8	219
HP-200	20	508	56	1422	72	1829	13	330	78	1981	14	356	16	406	9	229	12 3/4	324
HP-300	24	610	60	1524	75	1905	15	381	81	2057	18	457	18	457	9	229	12 3/4	324
HP-500	30	762	69 3/4	1772	80	2032	18 1/2	470	77 1/2	1968	23	584	21	533	12	305	14	356
HP-750	36	914	82 1/2	2095	92	2337	21	559	98	2489	28	711	24	610	12	305	16	406
HP-1000	42	1067	91	2311	106	2692	24	610	114	2896	32	813	27	686	12	305	16	406
HP-1500	48	1219	95	2413	120	3048	27	686	128	3251	38	965	30	762	12	305	20	508
HP-1800	54	1372	110	2794	132	3353	30	762	142	3607	42	1067	33	838	10	254	20	508
HP-2000	60	1524	119	3023	144	3658	30	762	154	3912	48	1219	36	914	10	254	20	508

All dimensions, weights and volumes are approximate and for estimating purposes only.



Facet wafer repacks, used with Facet HP Series single-stage coalescer housings, are excellent coalescers or strainers for fuel applications when gross solids (in excess of 0.5 ppm) and heavy water contamination conditions exist.

Heavy solids or certain types of solids tend to either blind off the surface of the repack media and/or compress only the first and second wafers to the point that they will no longer function as a coalescer. With Facet wafer repacks, only the first two wafers need to be replaced when required while the third and successive downstream wafers require fewer change outs since they generally remain relatively free of solids.

In constructing wafer repacks Facet controls the media density by machine packing the excelsior between metal wheel type grids and hardware cloth, then securely tying each end with heavy metal wire to prevent deformation during operation. To assure a tight fit inside the housing and prevent bypass, the outside diameter of each repack is strategically sized to the inside diameter of the housing wall.

Facet HP Series single-stage coalescers installed with Facet excelsior wafer repacks will provide excellent protection to fueling systems when both gross solids and heavy water contamination conditions are present.



### CARTRIDGE STYLE

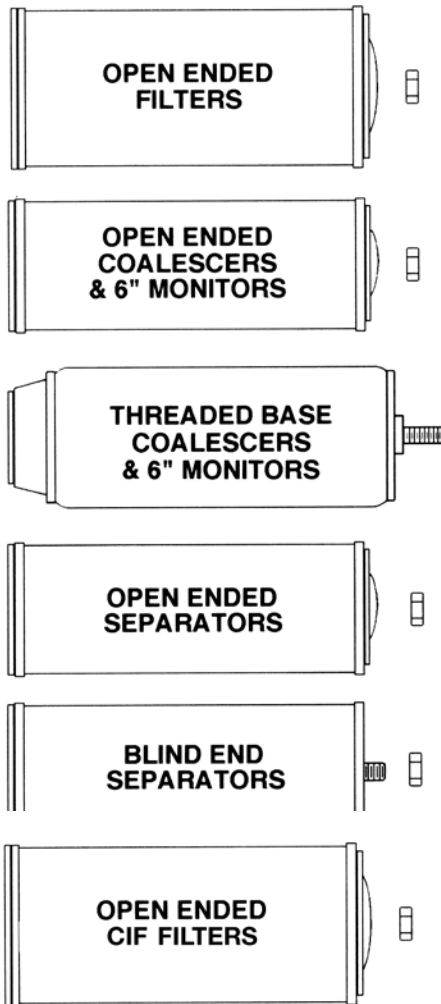

### RECOMMENDED SEALING TORQUE

FLAT SEAL 15 LBS. FT.  
KNIFE EDGE SEAL 10 LBS. FT.

FLAT SEAL 20 LBS. FT.  
KNIFE EDGE SEAL 10 LBS. FT.

SCREW BASE 30 LBS. FT.

FLAT SEAL 7 LBS. FT.  
KNIFE EDGE SEAL 5 LBS. FT.

FLAT SEAL 7 LBS. FT.  
KNIFE EDGE SEAL 5 LBS. FT.

FLAT SEAL 5 LBS. FT.  
KNIFE EDGE SEAL 5 LBS. FT.



TORQUE CONVERSION TABLE			
Pounds Foot	Pounds Inch	Kilograms-meter	Newton-Meter
5	60	.69	6.53
7	84	.97	9.14
10	120	1.38	13.05
20	240	2.77	27.10
30	360	4.15	39.15



For 6" OD (152 mm) 3½" ID (89 MM) 14½" (368 mm) LG CARTRIDGES

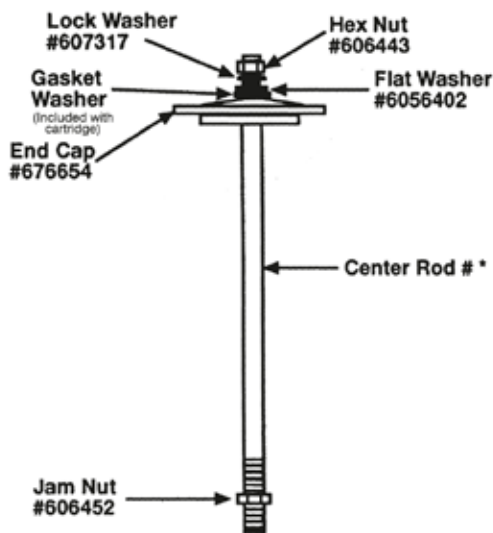

1 DEEP

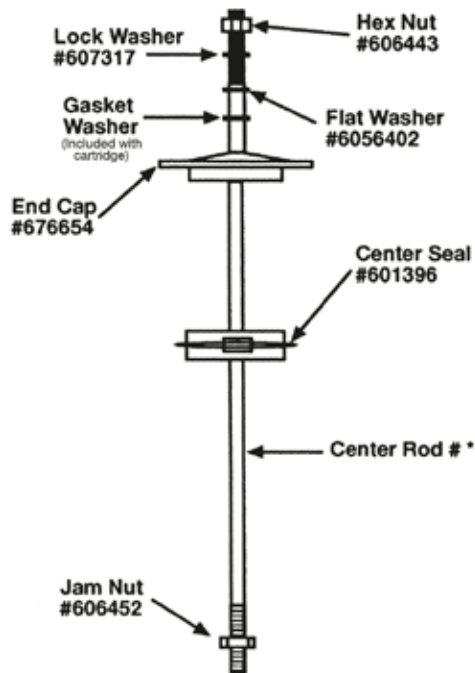

2 DEEP

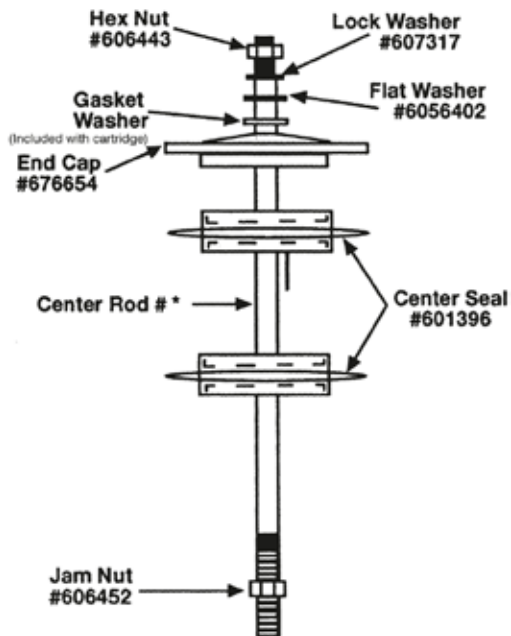

3 DEEP

CENTER ROD	
Overall Cartridge Length (in)	Part Number
14½	678901
28¾	678905
43¼	678907
57¼	678909

Note: Nuts, washers and center rods are stainless steel.





Top view



Side view with bolt



Bottom view



Side view

### Improved Design for Added Strength

Facet's screw base adapter has been redesigned to provide the strongest adapter on the market today. The adapter is now made of aluminum with increased locating pin strength when compared with other designs. Gasket material is Buna-N.

The adapter may be used with all Facet 6" (152 mm) diameter screw base cartridges and is compatible with cartridges from other manufacturers.

The design is compatible with all aviation fuels and provides a temperature range up to 240 °F (115 °C). It is also interchangeable with Velcon's 6000T screw base adapter.

PART NUMBER	COMMENTS
677453A-AM*	1/2" bolt for Facet Vessels
677453A-375-AM*	3/8" bolt for Velcon Vessels

\*Complete Assembly including adapter, gasket, bolt and washers.



It is recommended that this procedure is carried out with every coalescer change to ensure full potential and longer life of the separator. Make sure hands are kept clean and free of grease or other contamination throughout the cleansing operation. It is also recommended that gloves (preferably thin rubber) be worn throughout this operation so as to avoid contact between bare hands and the separator screen / mesh.

1. CAREFULLY remove each element from the filter separator.
2. Submerge the element in clean, dry fuel and wash it using a gentle, reciprocating action, holding the element first by one end cap and then the other. (DO NOT touch the separator screen/mesh with your bare hands, or allow any grease to come into contact with the element.)
3. Holding the element by the endcaps, visually inspect the entire surface of the screen for damage and contamination. If there are any visible flaws or debris that have not been removed by washing, the cartridge should be replaced.
4. While separator is fuel wet, hold the element horizontal and allow tap water to drip onto the screen. The water must not be sprayed and it must not fall more than 3" (7.5 cm) before contacting the screen. The water will run off instantly if the element is not contaminated. Continue testing the element by slowly rotating and moving it back and forth until the entire surface has been tested. If the water does not run off, but disappears through the screen and is found inside the element, then the element has to be further cleaned as described in step 6.
5. If the element passes the surface inspection (step 3) and the water test (step 4), rinse it thoroughly in clean fuel to remove traces of water and air dry prior to reinstalling.
6. If the element fails the water test (step 4), it may be further cleaned by repeating the cleaning stage (step 2) using isopropyl alcohol in place of fuel. After cleaning, the element should be drained and rinsed in clean, dry fuel to remove all traces of isopropyl alcohol if used. Another alternative is to use a spray of hot water (not from a pressure washer). Allow the cartridge to fully dry. After using either procedure, repeat the water test (step 4). If the element does not pass the water test after this operation, it must be replaced.
7. If there are visible tears, nicks, or cuts, they can be repaired as long as they are not larger than 1/8" in diameter. Use brightly colored fingernail polish or epoxy to repair the area. The nail polish allows repairs to be easily observed in the future. After you have repaired the element, wet the element in fuel and repeat the water test (step 4).

NOTE: The use of detergents (i.e., soap, powder cleanser of any kind), steam, or compressed air during any of the above operations IS NOT RECOMMENDED because they can affect the operation of the separator.





### 1. What is the operational life expectancy of the Teflon and Synthetic cartridge?

Facet Teflon & Synthetic separator cartridges are cleanable and reusable. They should be inspected and tested before reusing. Cartridge service life should not be extended beyond 3 years. Follow Facet cleaning procedures for Teflon and Synthetic cartridges.

### 2. What is the shelf life expectancy of the Facet cartridges?

Most elements are a minimum of five years if sealed and in temperature controlled environment. Monitor should be installed within 2 years of shipment from Facet stock.

### 3. When do I change out my coalescer separator?

- A. Coalescer elements must be replaced when:
1. Filter Membrane (Milipore<sup>®</sup>) Test indicates elements are not performing (Refer to Section 3).
  2. Corrected Differential pressure exceeds 15 psi or there is a sudden drop in differential pressure.
  3. Continuous sump samples indicate surfactants, microbial or solid contaminants.
  4. Free water detection test indicates elements are not performing (Ref. Section 3-3).

### 4. Is there a minimum flow rate coalescer separators?

Operating a coalescer separator at less than 25% of rated flow, along with extended periods of inactivity, can increase the risk for microbiological growth on the elements due to free water not being released from the coalescer.

### 5. What is the typical clean differential pressure drop?

Filter/separators	2-4 psid clean at ambient temp.
Micronic Filters	.5-4 psid clean at ambient temp.
2" Monitors	6-7 psid clean at ambient temp.
6" Monitors	3-4 psid clean at ambient temp.

### 6. Typical element change-out recommendations at maximum rated flow.

Filter/Separators	15 psid
Monitors	15 psid
Micronics	15 psid
"HP"	15 psid
Clays	Based on MSEP test

### 7. What is the rupture pressure for each element?

Filter/Separators	75 psid
Monitors	174 psid
Micronics	75 psid
"HP"	15 psid
Clays	N/A

### 8. What is the purpose of the Slug valve?

The slug valve stops the flow of product when excessive water is collected in the coalescer separator sump. It works in conjunction with the float control. The slug valve can also be furnished with rate of flow control which is used to control flow through the coalescer separator and with a check valve feature to prevent back-flow.

---

## Frequently Asked Technical Questions

### 9. What is the operation of a Water Probe?

The water probe detects the level of water electronically and then can open and close the auto water drain valve or slug valve, shut down pump and send alarm to control panel.

### 10. What is the reason for a Clay Treater?

The clay treater removes surfactants from fuel to allow coalescer separators to perform properly. The surfactants will disarm the coalescer elements.

### 11. What is the function of the vessel heaters?

The heater keeps water from freezing in the sump and drain lines.

### 12. What data do you need to know to size a vessel?

Refer to Application Data Sheet in your catalog.

### 13. Which should be used, clay bags or canisters?

Canisters have gaskets that improve sealing and have less chance of bypassing. Bags, on the other hand, hold more clay and cost about 40% less.

### 14. Can clay bags be used in Velcon vessels?

Not usually. Velcon vessels are built similar to "M" series filter vessels except without adaptors for cartridge sealing. They use center rods, center seals, and end caps. There are conversion kits but are cost prohibitive. Two things to remember, this can be a tremendous selling tool for Facet vessels, but it does add additional cost.

### 15. What colors are used for what fuels?

Jet - Clear  
AV Gas - Blue,  
High Sulfur Diesel - Red.

### 16. Can dye (color) in fuels be removed?

In most instances, "no."

### 17. Why use horizontal versus vertical housing?

Space and ease of maintenance.

### 18. Should a filter be installed upstream of a coalescer separator?

Depends on the application. If the customer is having a problem with solids you should definitely have a micron filter in front of your coalescer separator. The micron filter is anywhere from a third to a fourth of the cost and has four times the surface area.

### 19. What is the difference between free and entrained and dissolved water?

1. Free water is created when the fuel has all the water it can dissolve plus more. This extra water is then free water. Free water is usually not visible as a haze until you get above 30 to 40 ppm free water. This free water is all that a coalescer or absorbent cartridge can remove.
2. Entrained water: Discrete water droplets carried by a continuous liquid or gas phase when water is immiscible with the liquid. May be separated from the continuous phase by coalescing and gravity separation. Usually picked up in a system by condensation or a water washing used in process.
3. Dissolved water is the water that is in solution or basically not visible in the fuel. The amount changes with temperature. Fuel holds more water as the temperature increases.

### 20. Is the delta P gauge on a clay treater actually telling you anything?

Not really. This is a common misconception. The only true way to tell if the clay is working is to take a MSEP test. This test will be taken on the inlet and the outlet and compared. The reading from the outlet should be higher. A good quality fuel has a reading of 85 or better. The closer you get to 100 the better the fuel quality. If the fuel going in is 80 and the outlet is 80 or less, you would need to change out the clay.

### 21. How many pounds of solids does our MP series filter element hold?

Up to 3-5 pounds per 14" length dependent upon the micron rating and type of solids present.

### 22. With AVGAS, can you flow more through the same coalescer separator?

The Energy Institute has extended Specification EI 1581 to include Av-Gas that is hydrocarbon based and has aromatics content that is similar to Jet Fuel under Category C sizing and flow.

### 23. What is the recommended sealing torque on screw base cartridges?

30 lbs. Ft.

### 24. What is the mesh size and micron rating of Facet's Synthetic separator?

50 micron, 267 mesh.

### 25. What are the benefits of Facet's CIF Cartridge?

No metal components, less expensive while maintaining high efficiency of M Series elements and reduced disposal volume and cost.

### 26. Does the size of the water droplets indicate the coalescing efficiency?

Downstream: Yes, the bigger the drops the more the fall. Saves Separator from having to do anything.

### 27. How is the gallon per minute of the coalescer calculated?

Flow per linear inch which is based on EI test (Jet Fuel).

### 28. Can our immersion heaters be wired for a signal light?

Yes.

### 29. What are certificates of similarity?

To provide certificate of test data in similar type vessels using flow rates that determine the correct amount of coalescers and separators. Upgrading an older vessel to EI 1581 current edition or changing from competitor vessel to Facet.

### 30. Are Material Safety Data Sheet (MSDS) required for the products manufactured by Facet?

Items manufactured by Facet are considered "articles" by definition of the regulations and therefore do not need MSDS sheets.

### 31. What is the correct procedure for draining the sump on a coalescer separator?

Per ATA-103 guidelines, drain fuel at maximum practical flow into a suitable container. The vessel must be pressurized, but fuel does not have to be flowing.



**1. APPLICATION:** \_\_\_\_\_

**2. OPERATING CONDITIONS AT POINT OF INSTALLATION:**

- A.** PRODUCT: \_\_\_\_\_ **B.** SPECIFIC GRAVITY: \_\_\_\_\_ @ \_\_\_\_\_ °F
- C.** FLOW RATE: \_\_\_\_\_ GPM **D.** TEMPERATURE: \_\_\_\_\_ °F.
- E.** PRESSURE: \_\_\_\_\_ PSIG
- F.** VISCOSITY: \_\_\_\_\_ SSU CS CP @ \_\_\_\_\_ °F and \_\_\_\_\_ SSU CS CP @ \_\_\_\_\_ °F
- G.** CONTAMINANTS: SOLIDS: \_\_\_\_\_ (% WT.) (% VOL.) LIQUID: \_\_\_\_\_ % VOLUME
- H.** DESCRIPTION OF SOLIDS: \_\_\_\_\_
- I.** PREVAILING PARTICLE SIZE RANGE: \_\_\_\_\_
- J.** DESCRIPTION OF LIQUID: \_\_\_\_\_
- K.** pH OF LIQUID OR PRODUCT: \_\_\_\_\_ TYPE AND % OF CONCENTRATION: \_\_\_\_\_

**3. REQUIRED PERFORMANCE EFFICIENCY:**

- A.** DESIRED PARTICLE RETENTION (MICRON): \_\_\_\_\_
- B.** MAXIMUM ALLOWABLE INITIAL PRESSURE DROP: \_\_\_\_\_ PSID

**4. MECHANICAL DESIGN CONDITIONS:**

- A.** DESIGN PRESSURE: \_\_\_\_\_ PSIG
- B.** DESIGN TEMPERATURE: \_\_\_\_\_ °F.
- C.** CORROSION ALLOWANCE: \_\_\_\_\_
- D.** CODE OR SPECIFICATION: \_\_\_\_\_ ASME? \_\_\_\_\_ ASME STAMP? \_\_\_\_\_ OTHER?
- E.** FLOW RATE: \_\_\_\_\_ GPM
- F.** MATERIALS OF CONSTRUCTION: \_\_\_\_\_
- G.** INLET AND OUTLET CONNECTIONS:  
SIZE: \_\_\_\_\_ FLANGED  FEMALE NPT  GROOVED  OTHER
- H.** OTHER CONNECTIONS ON VESSEL:
- | CONNECTION FOR | SIZE  | FLANGED                  | THREADED                 |
|----------------|-------|--------------------------|--------------------------|
| PRESSURE GAUGE | _____ | <input type="checkbox"/> | <input type="checkbox"/> |
| RELIEF         | _____ | <input type="checkbox"/> | <input type="checkbox"/> |
| VENT           | _____ | <input type="checkbox"/> | <input type="checkbox"/> |
| DRAIN          | _____ | <input type="checkbox"/> | <input type="checkbox"/> |
- I.** SPECIAL DESIGN FEATURES: \_\_\_\_\_

**5. ACCESSORY ITEMS:**

- A.** DIFFERENTIAL PRESSURE GAUGE? \_\_\_\_\_ DIRECT READING? \_\_\_\_\_  
WITH DEAD HAND? \_\_\_\_\_ NON-DIRECT READING? \_\_\_\_\_
- B.** MANUAL VENT VALVE? \_\_\_\_\_ **C.** PRESSURE RELIEF VALVE? \_\_\_\_\_
- D.** MANUAL DRAIN VALVE? \_\_\_\_\_ **E.** INTERNAL EPOXY COATING? \_\_\_\_\_
- F.** AIR ELIMINATOR? \_\_\_\_\_ **G.** HEAD OPENING DEVICE? \_\_\_\_\_

---

# Liquid Filtration Application Information

**6. BECAUSE OF COMPATIBILITY OR OTHER REASONS, DO YOU HAVE ANY PREFERENCE FOR THE FOLLOWING:**

HOUSING:

- CARBON STEEL
- ALUMINUM
- STAINLESS
- OTHER \_\_\_\_\_

\_\_\_\_\_

GASKET:

- BUNA-N
- VITON A
- TEFLON®
- OTHER \_\_\_\_\_

\_\_\_\_\_

CARTRIDGE:

- PAPER
- SCREEN
- GLASS FIBER
- OTHER \_\_\_\_\_

\_\_\_\_\_

**7. REMARKS:**

\_\_\_\_\_  
\_\_\_\_\_  
\_\_\_\_\_

**8. INSTRUCTIONS:** SUBMIT QUOTATION TO: CUSTOMER  DISTRIBUTOR

ORIGINAL & \_\_\_\_\_ COPIES REQUIRED

CUSTOMER \_\_\_\_\_

\_\_\_\_\_

\_\_\_\_\_

\_\_\_\_\_

DISTRIBUTOR \_\_\_\_\_

\_\_\_\_\_

\_\_\_\_\_

\_\_\_\_\_

**9. QUOTATION INFORMATION:**

NEED QUOTATION—HAVE ORDER FOR PROJECT? YES  NO

WILL ORDER IN: 0-6 MONTHS  LATER

NUMBER OF COMPETITORS QUOTING? \_\_\_\_\_

In cases where any data is unknown or not available, indicate accordingly.

Facet will contact you if further details are needed.

SUBMITTED BY: \_\_\_\_\_

\_\_\_\_\_

\_\_\_\_\_

\_\_\_\_\_

FOR: \_\_\_\_\_

\_\_\_\_\_

\_\_\_\_\_

\_\_\_\_\_

**1. APPLICATION:** \_\_\_\_\_

**2. OPERATING CONDITIONS AT POINT OF INSTALLATION:**

- A.** PRODUCT: \_\_\_\_\_
- B.** SPECIFIC GRAVITY: \_\_\_\_\_ @ \_\_\_\_\_ °F
- C.** FLOW RATE: \_\_\_\_\_ GPM
- D.** TEMPERATURE: \_\_\_\_\_ °F.
- E.** PRESSURE: \_\_\_\_\_ PSIG
- F.** VISCOSITY: \_\_\_\_\_ SSU CS CP @ \_\_\_\_\_ °F and \_\_\_\_\_ SSU CS CP @ \_\_\_\_\_ °F
- G.** INTERFACIAL TENSION: \_\_\_\_\_ DYNES PER CENTIMETER: \_\_\_\_\_
- H.** CONTAMINANTS: LIQUID: \_\_\_\_\_% VOLUME SOLIDS: \_\_\_\_\_ (% WT.) (% VOL.)
- I.** DESCRIPTION OF LIQUID: \_\_\_\_\_
- J.** pH OF LIQUID: \_\_\_\_\_ TYPE AND CONCENTRATION: \_\_\_\_\_
- K.** DESCRIPTION OF SOLIDS: \_\_\_\_\_
- L.** PREVAILING PARTICLE SIZE RANGE: \_\_\_\_\_
- M.** TYPE AND CONCENTRATION OF CORROSION INHIBITORS, IF ANY: \_\_\_\_\_

**3. REQUIRED PERFORMANCE EFFICIENCY:**

- A.** ALLOWABLE ENTRAINMENT IN EFFLUENT: \_\_\_\_\_
- B.** DESIRED PARTICLE RETENTION (MICRON): \_\_\_\_\_
- C.** MAXIMUM ALLOWABLE INITIAL PRESSURE DROP: \_\_\_\_\_ PSID

**4. MECHANICAL DESIGN CONDITIONS:**

- A.** DESIGN PRESSURE: \_\_\_\_\_ PSIG
- B.** DESIGN TEMPERATURE: \_\_\_\_\_ °F.
- C.** CORROSION ALLOWANCE: \_\_\_\_\_
- D.** CODE OR SPECIFICATION: \_\_\_\_\_ ASME? \_\_\_\_\_ ASME STAMP? \_\_\_\_\_ OTHER?
- E.** FLOW RATE: \_\_\_\_\_ GPM
- F.** MATERIALS OF CONSTRUCTION: \_\_\_\_\_
- G.** INLET AND OUTLET CONNECTIONS:  
 SIZE: \_\_\_\_\_ FLANGED  FEMALE NPT  GROOVED  OTHER
- H.** OTHER CONNECTIONS ON VESSEL:
 

CONNECTION FOR	SIZE	FLANGED	THREADED
PRESSURE GAUGE	_____	<input type="checkbox"/>	<input type="checkbox"/>
RELIEF	_____	<input type="checkbox"/>	<input type="checkbox"/>
VENT	_____	<input type="checkbox"/>	<input type="checkbox"/>
DRAIN	_____	<input type="checkbox"/>	<input type="checkbox"/>
LEVEL GAUGE	_____	<input type="checkbox"/>	<input type="checkbox"/>
LEVEL CONTROL	_____	<input type="checkbox"/>	<input type="checkbox"/>

**I.** SPECIAL DESIGN FEATURES: \_\_\_\_\_

**5. ACCESSORY ITEMS:**

- A.** DIFFERENTIAL PRESSURE GAUGE? \_\_\_\_\_ DIRECT READING? \_\_\_\_\_  
 WITH DEAD HAND? \_\_\_\_\_ NON-DIRECT READING? \_\_\_\_\_
- B.** MANUAL VENT VALVE? \_\_\_\_\_
- C.** PRESSURE RELIEF VALVE? \_\_\_\_\_
- D.** LEVEL GAUGE? \_\_\_\_\_ TUBULAR? \_\_\_\_\_ REFLEX? \_\_\_\_\_ TRANSPARENT? \_\_\_\_\_

---

# Liquid Separation Application Information

## 5. ACCESSORY ITEMS (Continued):

- E.** MANUAL DRAIN VALVE? \_\_\_\_\_ **F.** LEVEL CONTROL (DUAL GRAVITY)? \_\_\_\_\_  
**G.** SLUG & DRAIN VALVE ASSEMBLY? \_\_\_\_\_ RATE OF FLOW CONTROL? \_\_\_\_\_ FLOAT TESTER?  
MATERIALS FOR SLUG VALVE: \_\_\_\_\_ CAST STEEL \_\_\_\_\_ DUCTILE IRON \_\_\_\_\_ OTHER  
**H.** IMMERSION HEATER \_\_\_\_\_ SUMP \_\_\_\_\_ DRAIN \_\_\_\_\_ VOLTAGE \_\_\_\_\_ INSULATION? \_\_\_\_\_  
**I.** STEEL SUPPORT STAND (FOR HORIZONTAL VESSELS ONLY)? \_\_\_\_\_  
**J.** INTERNAL EPOXY COATING? \_\_\_\_\_ **K.** AIR ELIMINATOR? \_\_\_\_\_  
**L.** HEAD OPENING DEVICE? \_\_\_\_\_

## 6. BECAUSE OF COMPATIBILITY OR OTHER REASONS, DO YOU HAVE ANY PREFERENCE FOR THE FOLLOWING:

- |                                       |                                      |                                      |
|---------------------------------------|--------------------------------------|--------------------------------------|
| HOUSING:                              | GASKET:                              | CARTRIDGE:                           |
| <input type="checkbox"/> CARBON STEEL | <input type="checkbox"/> BUNA-N      | <input type="checkbox"/> PAPER       |
| <input type="checkbox"/> ALUMINUM     | <input type="checkbox"/> VITON A     | <input type="checkbox"/> SCREEN      |
| <input type="checkbox"/> STAINLESS    | <input type="checkbox"/> TEFLON®     | <input type="checkbox"/> GLASS FIBER |
| <input type="checkbox"/> OTHER _____  | <input type="checkbox"/> OTHER _____ | <input type="checkbox"/> OTHER _____ |
| _____                                 | _____                                | _____                                |
| _____                                 | _____                                | _____                                |

## 7. REMARKS:

---

---

---

## 8. INSTRUCTIONS: SUBMIT QUOTATION TO: CUSTOMER DISTRIBUTOR

ORIGINAL & \_\_\_\_\_ COPIES REQUIRED

CUSTOMER \_\_\_\_\_  
\_\_\_\_\_  
\_\_\_\_\_  
\_\_\_\_\_

DISTRIBUTOR \_\_\_\_\_  
\_\_\_\_\_  
\_\_\_\_\_  
\_\_\_\_\_

## 9. QUOTATION INFORMATION:

- NEED QUOTATION—HAVE ORDER FOR PROJECT? YES  NO   
WILL ORDER IN: 0-6 MONTHS  LATER   
NUMBER OF COMPETITORS QUOTING? \_\_\_\_\_

In cases where any data is unknown or not available, indicate accordingly.  
Facet will contact you if further details are needed.

SUBMITTED BY: \_\_\_\_\_  
\_\_\_\_\_  
\_\_\_\_\_  
\_\_\_\_\_

FOR: \_\_\_\_\_  
\_\_\_\_\_  
\_\_\_\_\_  
\_\_\_\_\_



**DONALDSON COMPANY, INC.**

**IMPORTANT NOTICE:** Many factors beyond the control of Donaldson can affect the use, performance, or results of Donaldson products or services in a particular application, including the conditions impacting how the products or services are selected, used, installed, or maintained. Because these factors are uniquely within the user's knowledge and control, it is essential the user evaluate both the products and any related services to determine their suitability for the user's intended purpose and application, including fitness for the particular purpose. All products, services, product specifications, availability and data are subject to change without notice and may vary by region or country.

© 2026 Donaldson Company, Inc. All rights reserved. Donaldson Company, Inc. reserves the right to change or discontinue any model or specification at any time and without notice.

F1107-2026-WW-Aviation-Catalog-temp

[www.facetfiltration.com](http://www.facetfiltration.com) | [facet@facetfiltration.com](mailto:facet@facetfiltration.com)



Donaldson®  
Facet™