

Fuel-Gard® VF-21SB/22SB Filter Water Separator

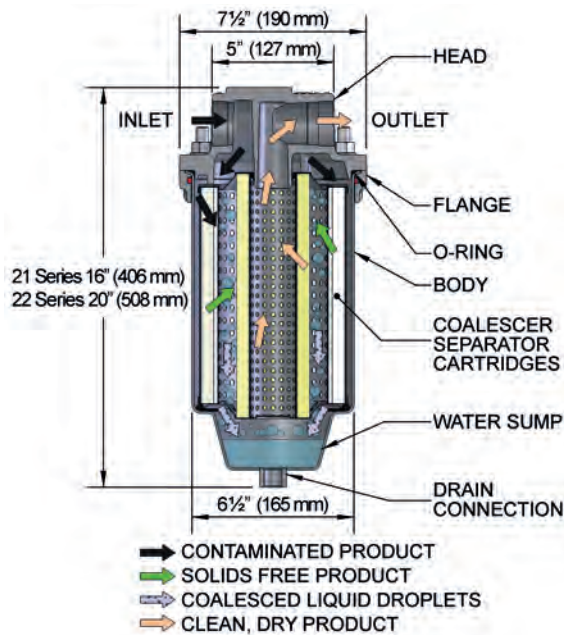

Differential Pressure Indicator -
The piston-type differential pressure indicator provides a simple visual warning. When 15 psi (1.03 bar) differential pressure is reached, the gauge indicator moves from green to red zone. This warning will prevent premature cartridge change-out.

The Facet VF-21SB/22SB, when configured as a filter water separator, is an economical, compact housing designed to remove water and solids from aviation fuels.

Both interior and exterior surfaces of the carbon steel body are epoxy coated to protect against corrosion.

This sturdy, single cartridge housing is easy to maintain and requires only 2" (51 mm) base clearance for cartridge change out.

Standard Housing Design

- Carbon steel body
- Aluminum head
- Epoxy coated internally and externally
- 150 psi (10.3 bar) design pressure
- Swing bolt quick open closure
- Buna-N o-ring closure gasket
- Vent and drain connections w/ brass petcocks provided
- 1½" NPT inlet and outlet connections

VESSEL OPTIONS

MODEL	DESCRIPTION
VF-21SB	Housing only
VF-21SB-PG	Housing w/ Direct Reading Differential Pressure Gauge
VF-21SB-PGS	Housing w/ Direct Reading Differential Pressure Gauge & Sight Glass (not for Avgas 100 LL)
VF-21SB-PGWP	Housing w/ Direct Reading Differential Pressure Gauge & ¾" NPT Coupling for Water Probe
VF-21SB-S	Housing w/ Sight Glass (not for Avgas 100 LL)
VF-21SB-WP	Housing w/ ¾" NPT Coupling for Water Probe
VF-21SB-PG2	Housing with 1/8" NPT thread connection to accommodate an external differential pressure gauge (supplied by others)
VF-22SB	Housing only
VF-22SB-PG	Housing w/ Direct Reading Differential Pressure Gauge
VF-22SB-PGS	Housing w/ Direct Reading Differential Pressure Gauge & Sight Glass (not for Avgas 100 LL)
VF-22SB-PGWP	Housing w/ Direct Reading Differential Pressure Gauge & ¾" NPT Coupling for Water Probe
VF-22SB-S	Housing w/ Sight Glass (not for Avgas 100 LL)
VF-22SB-WP	Housing w/ ¾" NPT Coupling for Water Probe
VF-22SB-PG2	Housing with 1/8" NPT connection to accommodate an external differential pressure gauge (supplied by others)
VF-22SB-PG2WP	Housing w/ 1/8" NPT thread to accept compatible Gammon or Schultz DP Pressure Gauge & ¾" NPT Coupling for Water Probe
644160	Mounting Bracket
644964	Grounding Cable
606521	Closure O-Ring

Water Sight Glass - The water sight glass provides an easy means to detect water in the sump. The weighted ball, visible in the sight glass, will float only when water is present. The floating ball is an indication water should be drained from the housing to prevent both cartridge contamination and water traveling downstream from the housing. Not for Avgas 100 LL.

ACCORDING TO THE REQUIREMENTS OF EUROPEAN PRESSURE EQUIPMENT DIRECTIVE (PED) 2014/68/EU ART. 4.3, WITHIN THE OPERATING LIMITS PROVIDED ON VESSEL NAMEPLATE AND SUMMARIZED BELOW, THESE FILTERS ARE DESIGNED AND MANUFACTURED IN ACCORDANCE WITH THE SOUND ENGINEERING PRACTICE AND EXEMPT FROM CE MARKING AND CERTIFICATION: 10 BAR(G) @ 35°C FOR AV-GAS AND JET FUEL.

Fuel-Gard® VF-21SB/22SB Filter Water Separator

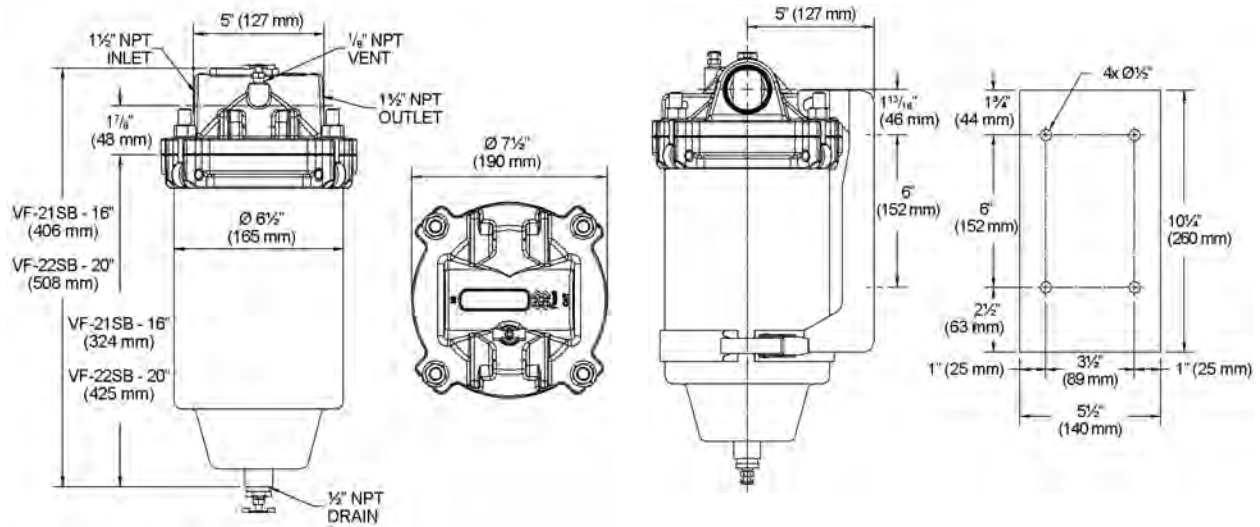

Optional Bonding Kit

The purpose of this bonding kit is to lessen the potential for static charge build up in the metal body of these vessels. This kit will allow the bowl, previously isolated because of the epoxy powder coating, to be bonded to system piping. One end of the bonding wire consists of a clamp that tightens onto the 1-1/2" piping. The other end has a heavy duty spring clamp that can be attached to the drain line valve. Remember if placing either end on a painted surface to scratch down to bare metal to allow contact.

This kit, part # 644964 can be purchased separately for existing vessels.

Optional Mounting Bracket

VF21SB/22SB Series Coalescer Separator Cartridges



Facet VF-21SB/22SB Series coalescer separator cartridges provide long service life and high solids holding capacity with no unloading characteristics. These filter separator cartridges effectively remove water and solids from fuels.

Standard Design Features

- Recommended maximum operating temperature: 240 °F (115 °C)
- Maximum differential pressure: 75 psi (5.17 bar)
- Fluid pH range: 5 to 9
- Flow Direction: Outside to In

Materials

- Carbon steel structural components
- All metal components coated to protect against corrosion
- Standard gaskets are Buna-N—other materials available upon request

MODEL NUMBER	ELEMENTS	KEROSENE		AVIATION FUEL ⁽¹⁾		GASOLINE		DIESEL	
		gpm	lpm	gpm	lpm	gpm	lpm	gpm	lpm
VF-21SB	CC-21-7	35	132	15	57	45	170	23	87
VF-22SB	CC-22-7	50	189	21.2	80	60	227	30	114

1) Tested to meet the effluent requirements of EI 1581, 6th Edition, Category C & M, Type S-LW (Jet Fuel and AV-Gas).

* For applications other than AV-Gas and Jet Fuel, please contact the nearest Facet office.

**DP given for viscosity <2 cSt