



Standard Design Features

- Recommended maximum operating temperature: 180°F
- Maximum differential pressure: 75 psi (5.25 kg/cm²)
- pH range from 5 to 9
- Flow direction: Outside to in
- Cartridge dimensions: OD - 6" (152 mm), ID - 1 1/2" (38 mm), Nominal Length - 9" (229 mm)

Materials

- Carbon steel structural components
- All metal components coated to protect against corrosion
- Standard gaskets are Buna-N —other materials available on request

COMPRESSED AIR OR GAS

OPERATING PRESSURE	
psi	kg/cm ²
10	.70
25	1.76
40	2.80
50	3.50
75	5.25
100	7.0
150	10.5

FLOW RATES

MODEL NUMBER	MICRON RATING	MAX. RECOMMENDED FLOW RATE					
		DIESEL		KEROSENE		GASOLINE	
		gpm	lpm	gpm	lpm	gpm	lpm
FILTER SEPARATOR							
CC-21-7	1	23	87	35	133	45	170
CC-21B	10	23	87	35	133	45	170
CC-21C	25	23	87	35	133	45	170
FILTER							
CF-609-2PLO	2	45	170	45	170	45	170
CF-609-10PLO	10	45	170	45	170	45	170
CF-609-25PLO	25	45	170	45	170	45	170
ABSORPTIVE FILTER							
FG-O-609-2 ¹	1	18	68	36	136	45	170
GNG-609-5PL	5	18	68	36	136	45	170
GNG-609-25PL	25	18	68	36	136	45	170

1.- El Specification tested and approved.

MODEL LEGEND

HOUSING	SERIES	ELEMENT TYPE	OPTIONS
VFCS (filter separator) VF (filter) VFG (absorptive)	21 or 22	See table for element options	PU15 = 15 psi pop up indicator PU25 = 25psi pop up indicator PG = piston type S = sight glass

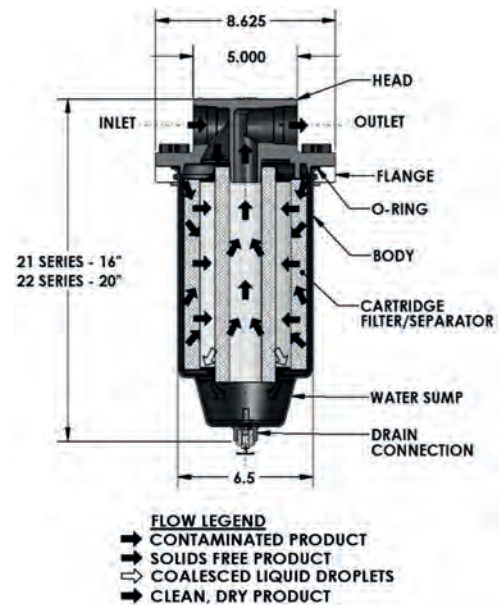



Standard Design Features

- Recommended maximum operating temperature: 180°F
- Maximum differential pressure: 75 psi (5.25 kg/cm²)
- pH range from 5 to 9
- Flow direction: Outside to in
- Cartridge dimensions: OD - 6" (152 mm), ID - 1 ½" (38 mm), Nominal Length - 12" (305 mm)

Materials

- Carbon steel structural components
- All metal components coated to protect against corrosion
- Standard gaskets are Buna-N —other materials available on request

COMPRESSED AIR OR GAS

OPERATING PRESSURE		FLOW
psi	kg/cm ²	scfm
10	.70	113
25	1.76	143
40	2.80	158
50	3.50	180
75	5.25	203
100	7.0	233
150	10.5	270

FLOW RATES

MODEL NUMBER	MICRON RATING	MAX. RECOMMENDED FLOW RATE					
		DIESEL		KEROSENE		GASOLINE	
		gpm	lpm	gpm	lpm	gpm	lpm
FILTER SEPARATOR							
CC-22-7	1	30	114	50	189	60	227
CC-22B	10	30	114	50	189	60	227
CC-22C	25	30	114	50	189	60	227
FILTER							
CF-612-2PLO	2	56	212	56	212	56	212
CF-612-10PLO	10	56	212	56	212	56	212
CF-612-25PLO	25	56	212	56	212	56	212
ABSORPTIVE FILTER							
FG-O-612-2 ¹	1	25	95	50	189	60	227
GNG-612-5PL	5	25	95	50	189	60	227
GNG-612-25PL	25	25	95	50	189	60	227

1.- El Specification tested and approved.

MODEL LEGEND

HOUSING	SERIES	ELEMENT TYPE	OPTIONS
VFCS (filter separator) VF (filter) VFG (absorptive)	21 or 22	See table for element options	PU15 = 15 psi pop up indicator PU25 = 25psi pop up indicator PG = piston type S = sight glass

